

MEGADOOR System 800/1000 Technical Information

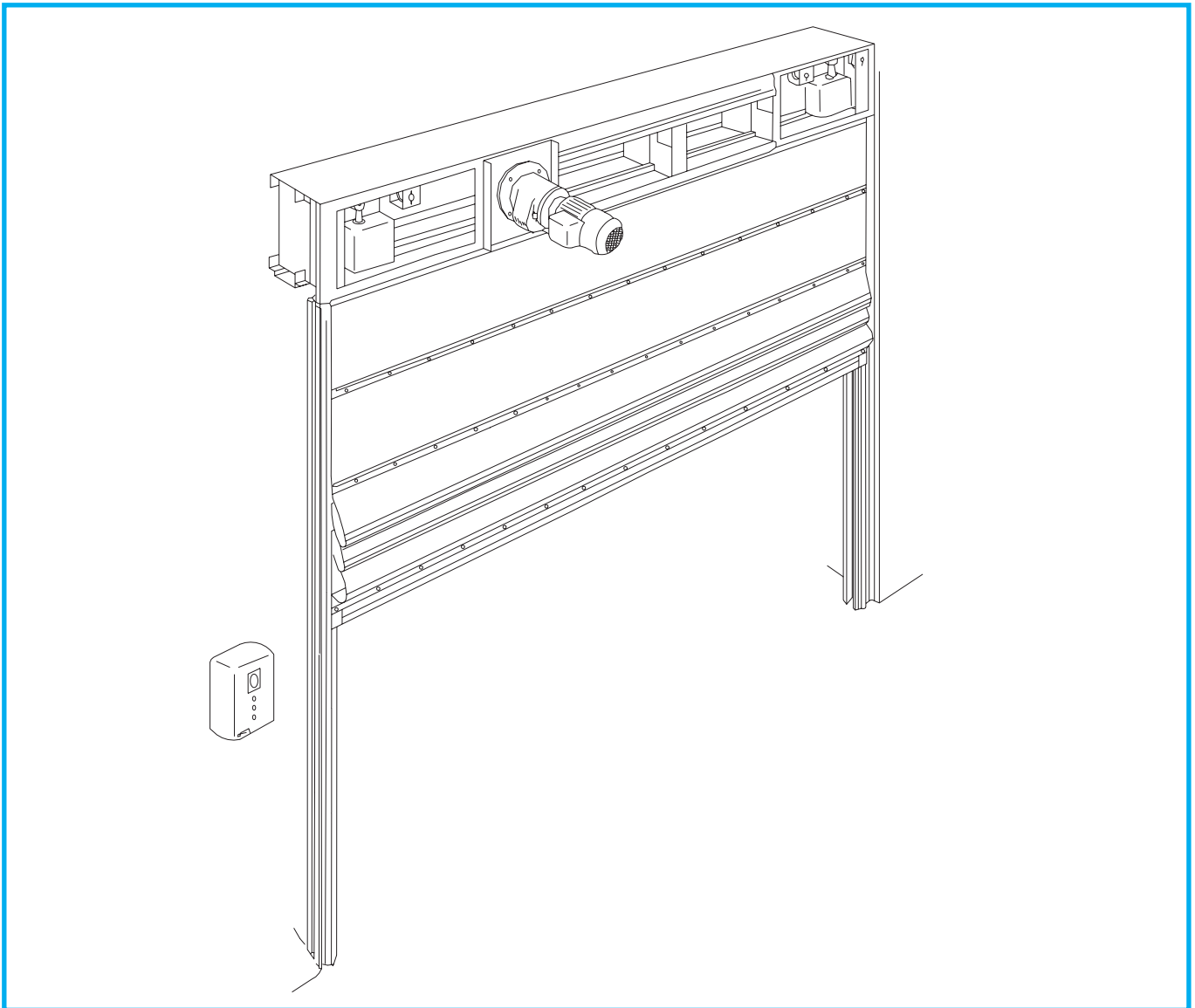

Technical information

MEGADOOR System 800 / 1000



The Megadoor was designed in about 1970 to solve the problem of doors in heavy industry. This revolutionising product was patented and thousands of doors have since been delivered to satisfied customers all over the world.

However, we are not resting on our success, work is continually in progress to improve products and maintain our lead in an increasingly competitive market.

Our doors are of course CE-marked, evidence that they conform to the directives that apply for deliveries in the European Market. Our activities are also certified according to ISO-9001: 2000, which is warranty for the fulfillment of our undertakings in relation to the customer and user. Megadoor S 800 / S 1000 complies with the European Standard EN 13241-1.

System 800 / System 1000 (S 800 / S 1000) are systems of industrial doors that are especially developed to cope with the specifications for durability, tightness, energy efficiency, operational reliability and minimum maintenance requirements of heavy industry.

For extremely corrosive environments the door leaf of S 800 / S 1000 can be delivered with stainless screws and steel components can be extra protected.

S 800 is available with extra-high opening speed for door openings subjected to intensive traffic, and both S 800 and S 1000 can be equipped with various modes of operation to minimize the passage cost.

S 800 / S 1000 may be mounted on the inside of a building, in the actual door opening, or on the outside (see page 6). To simplify its adaptation to a building, the header box of S 800 is available in a self-supporting version (see page 10).

S 800 / S 1000 are available for delivery with optional jambs if the existing fixing surface is not suitable for the guide rails (see page 11). The header box and motor can be protected in various ways (see page 12).

Technical data

	System 800 Performance:	System 1000 Performance:
Door leaf thickness	100 mm	160 mm
Normal opening speed:	0.2—0.3 m/s	0.2—0.3 m/s
Increased opening speed:	0.4—0.6 m/s	-
Maximum size:	Clearance width 8.7 m Clearance height 12 m	Clearance width 16 m Clearance height 20 m
Wind load (differential pressure) acc. to EN 12424:	0.7 kPa (class 3) to 8 m cl. width	0.7-1.6 kPa (class 3-5), depending on size
Stated values are standard, dimensioning for other pressures are fully possible.		
U-value (heat transmission coefficient): Varies with type and size of door		

Electrical system:

Control system	PLC-based
Protection class, control cabinet:	IP65
Protection class limit switches:	IP65
Protection class, motor/brake:	IP55
Protection class, push buttons:	IP65
Power supply:	3-phase 400 V 50 Hz (other alternatives available on request)
Control voltage:	24 V AC
Fusing:	16 A 20 A (25 A if twin motor version)
Free contacts:	6 for control of user functions.
Motor ratings:	0.37—3.3 kW and 1.6—3.7 kW per motor. S 1000 is supplied in twin motor version for CH>15 metre or for large door width.

Fabric data:

Basic fabric:	Polyester, 1100 dtex.
Weight:	700 g/m ²
Heat-and-cold resistance:	-35°C to +70°C.
Tensile strength warp/weft:	2700/2500 N/5 cm acc. to DIN 53354, EN ISO 1421
Tear resistance warp/weft:	370/320 N acc. to DIN 53363
Resistance to light:	6—8 (in a scale 0—8) acc. to BS 1006, ≥ 7 acc. to ISO 105-B02
UV stabilized:	Yes
Flame resistant:	Yes, acc. to SIS 650082, ASTM E84-94 class A, DIN 4102 B1
Mildew and rot resistant:	Yes
Lacquered:	Yes
Standard shades:	Tan NCS 2010Y-40R Yellow NCS S0570-Y20R Red NCS 2070-R Blue NCS S3560-R80B Green NCS 8010-G10Y Grey NCS 3500 White NCS 0500 Translucent white
Logotype:	Optional
Vision panels:	Optional

Surface treatment:

Steel components:	For corrosivity category C3 according to ISO 12944:2. Higher class on request.
Other parts:	Aluminium, plastic, stainless steel, zinc electro-plated steel (~10µ). Fixing elements are zinc electro-plated (~10µ).

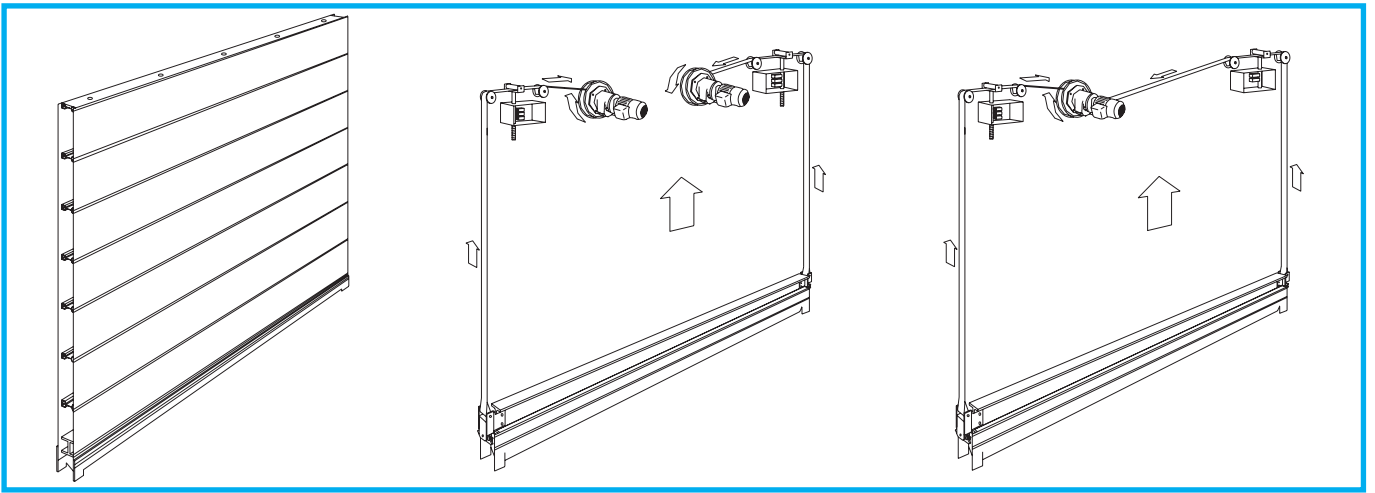

Door leaf

The door leaf consists of double vinyl-coated polyester fabric with intermediate aluminium sections. The bottom section is built up of steel and aluminium.

The door leaf is resistant to both mechanical abrasion, such as sand blasting, and to sparks in the immediate vicinity of the door, eg, caused by welding or gas-arc cutting.

Wind load is transferred to the vertical guide rails by the horizontal aluminium sections of the door leaf. The fully welded vinyl-coated polyester fabric prevents the intermediate sections from flopping or twisting.

Lubrication-free slide blocks, which travel in the guide rails, are provided at each end of the door leaf sections. A maintenance-free seal that is integrated with the guide rail ensures minimum leakage.

When opening, a polyester belt is wound up onto a belt drum to lift the bottom section.

For opening heights greater than about 15 metres the doors are delivered in a twin motor version that has two belt drums (see illustration).

The belt drum is mounted by a keyed joint directly on the output shaft of a braked reduction-gearred motor.

The motor is fitted with a hand operated brake release and it is adapted for simple emergency operation via a hand crank, without any need for tools.

The belt is insensitive to corrosion, dirt and dust.

Stainless steel safety arresters, against accidental falling of the door, are activated during each opening and closing operation and they also lock the door in the closed position. The safety function is tested by TÜV and the safety arrester is BG certified.

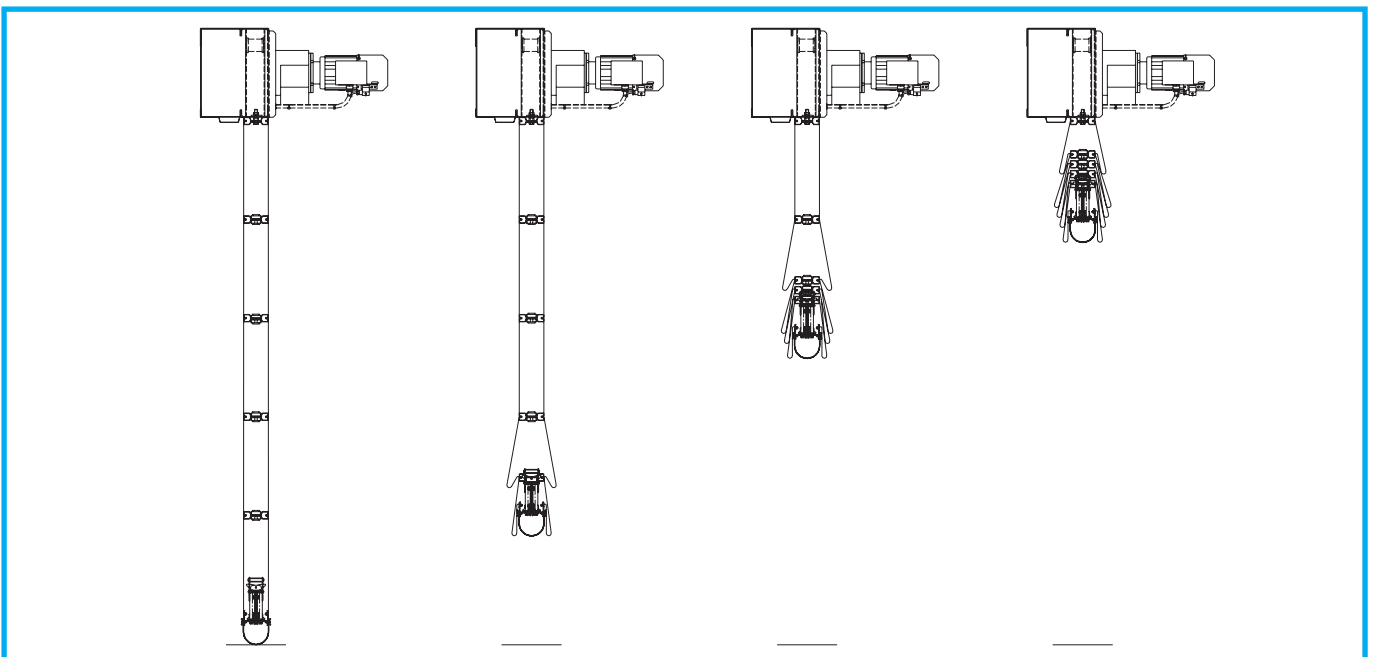

The polyester belts hoist the bottom section. The fabric folds into pleats as the door is opened and the aluminium sections are stacked on top of one another underneath the header box. In the event of differential pressure the fabric may tend to lie between the sections during the opening phase.

Various ways of installing S 800 / S 1000 in a building

System 800 / 1000 are easy to adapt to most types of openings. The door leaf is compressed during the opening phase and therefore a minimum of space is required, inside or outside of the building. If there are no solid surfaces on which to mount the door we can supply jambs. S 800 is also available in a self-supporting version. S 800 / S1000 is available in a version, including beam clamps, prepared for mounting the header box underneath an existing beam, type IPE 400.

The door is installed on-site by our installation organisation. To facilitate fitting, the site must be prepared in good time prior to installation.

A dimensional drawing, for approval by the customer, is enclosed with our quotation or order confirmation.

Mounting

There are three basic ways of fitting a Megadoor:

1. Internal wall mounting.
2. Fitting in a door opening.
3. External wall mounting.

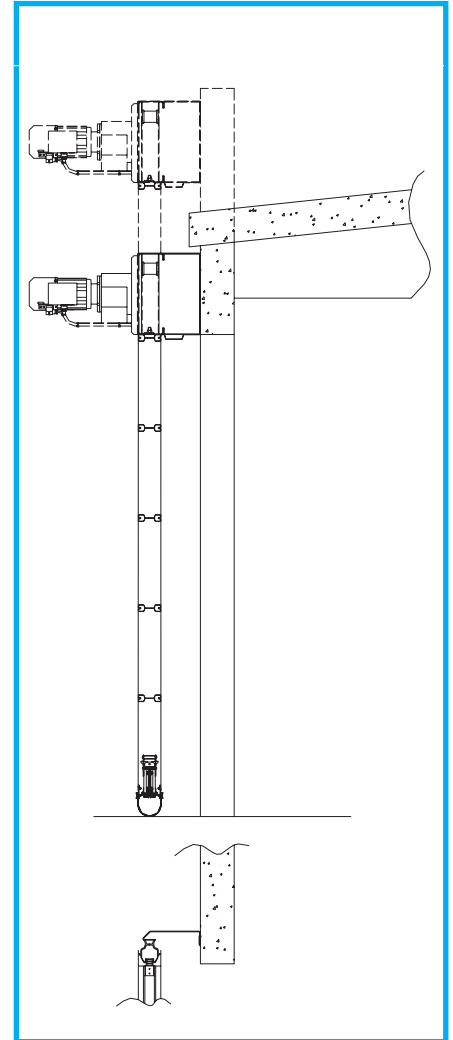
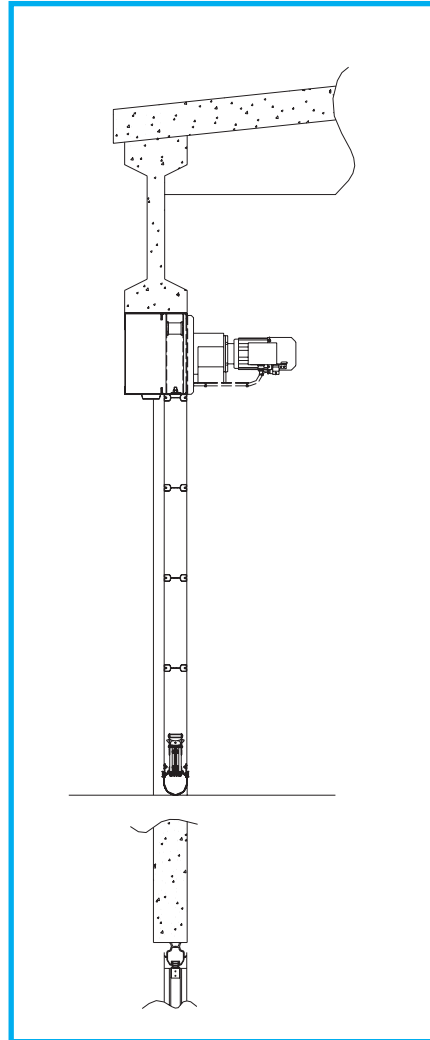
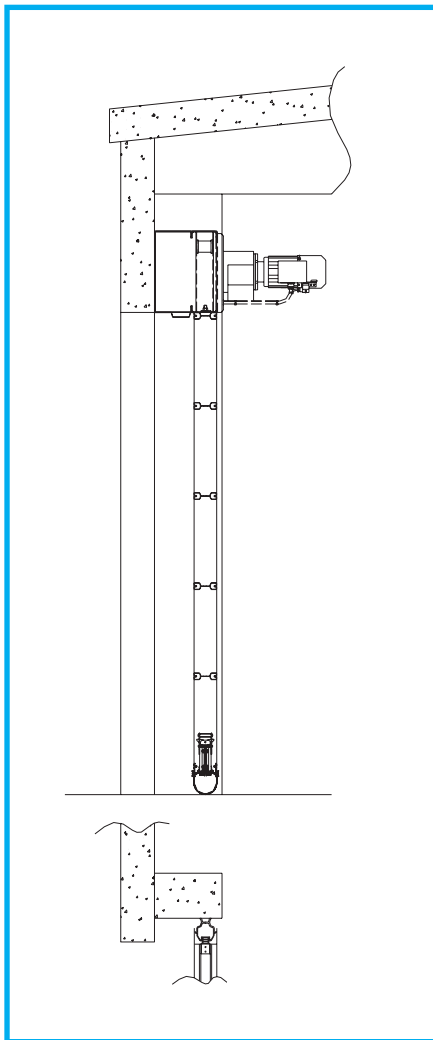

Internal wall mounting

Internal mounting is recommended where the size of the door opening permits. The drive machinery and guide rails will then be fully protected.

Fitting in a door opening

Mounting in the actual door opening is an excellent alternative where a door is to be fitted in an existing opening and where the risk of colliding with the guide rails is negligible. It is also possible, however, to protect guide rails with a collision shield.

External wall mounting

External mounting should be selected if the environment inside the building is severe or where there is insufficient space above the opening.

Load on the building with door closed

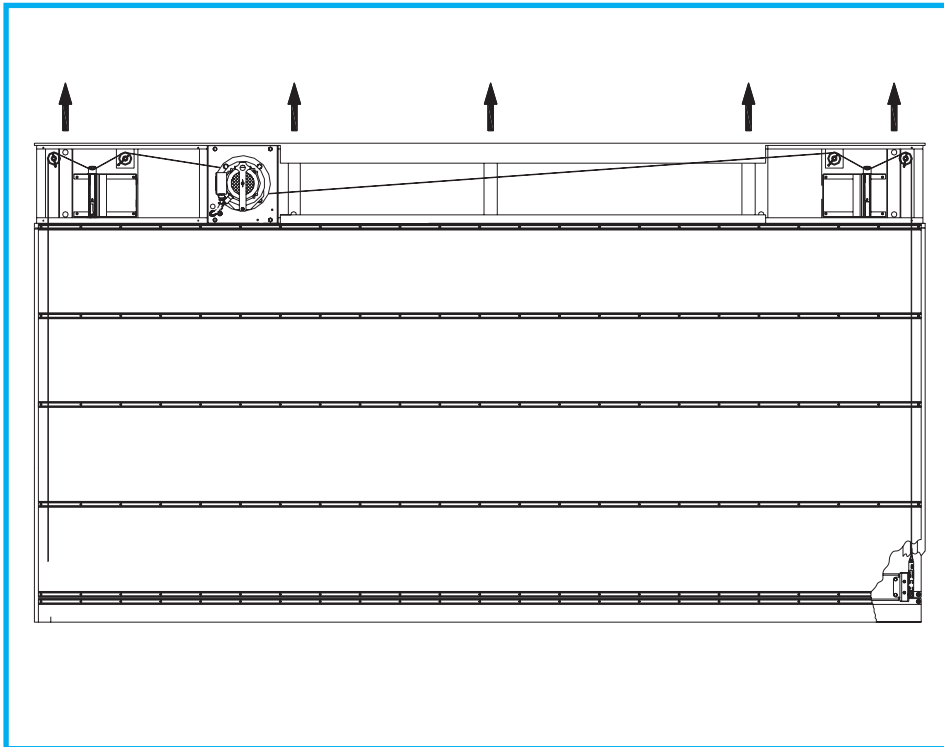

When the door is closed the total weight is distributed on the fixing points. The distance between fixing points is about 1000 mm. The door leaf of S 800 itself does not weigh more than 40 to 80 kg per metre width but, in view of the extra load which may result in the event of a collision, the total load on the building should be calculated at 1.5 kN/m. For S 1000 the corresponding values are 50 to 185 kg per metre width and 3 kN/m.

Load on the building with door opened

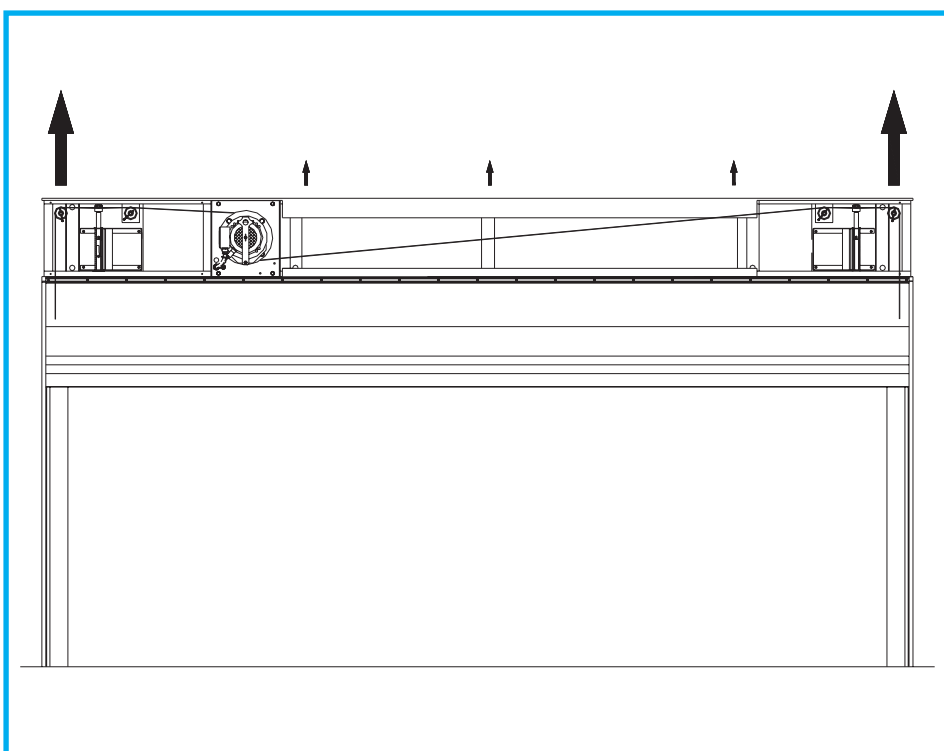

The load of the door leaf is successively transferred to the ends of the header box as the door is opened. In this situation it is mainly only the weight of the header box that rests on the other fixing points.

Mounting surfaces for the header box

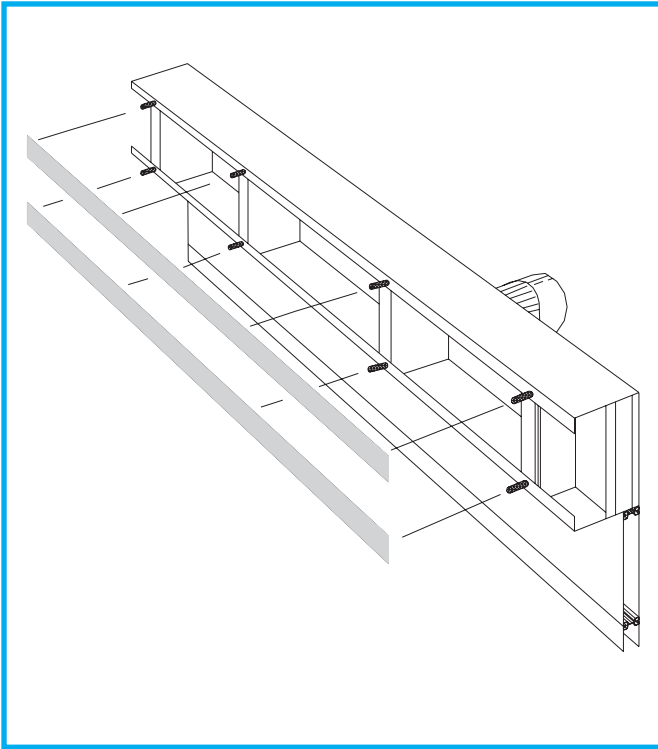

Mounting on wall

There must be flat vertical surfaces to secure the backside of the header box. (See shaded areas in the figure.)

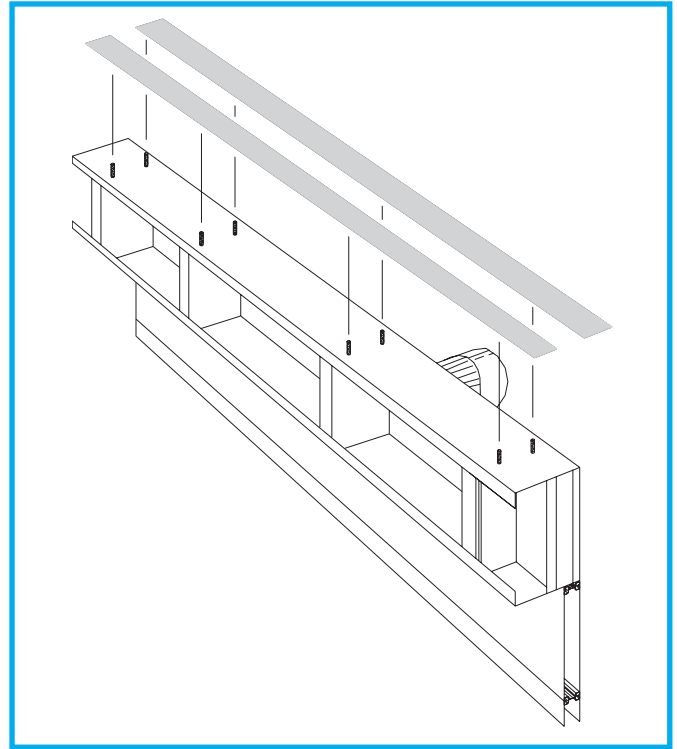

Mounting in opening

There must be flat horizontal surfaces to secure the top of the header box. (See shaded areas in the figure.)

Suitable mounting surfaces

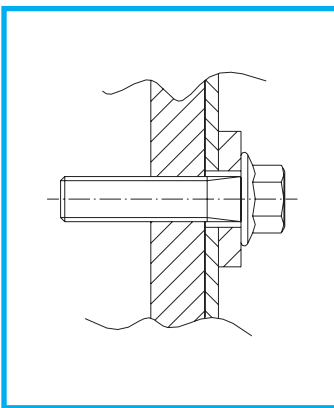

A. Steel

Secure the S 800 header box with self-threading screws. For S 1000 header box drill and tap for M12.

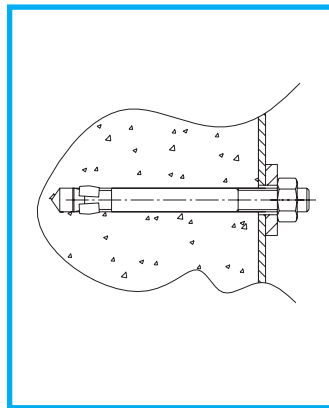

B. Concrete

Drill holes in the concrete for expansion screws with which to secure the header box.

Screw data

	S800	S1000
Screw dimension of	M10	M12
Strength class grade	8.8	8.8
Steel mounting surface	$t \geq 8$	$t \geq 10$
Concrete mounting surface	$t \geq 100$	$t \geq 110$

See also dimensional drawing page 17, 18, 19, 20, 21, 22.

Mounting surfaces for guide rails

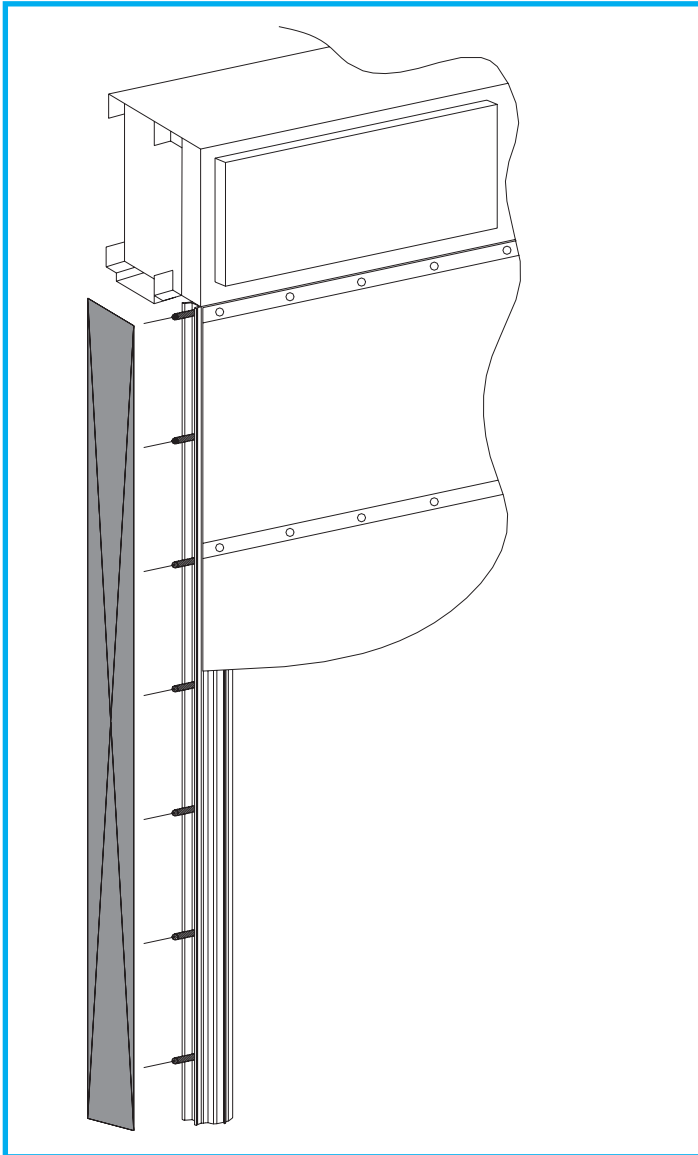

Suitable surfaces are required on which to mount guide rails (see shaded area in the figure). The mounting surfaces must be strong and smooth. Distance between the fixing points is about 1 metre.

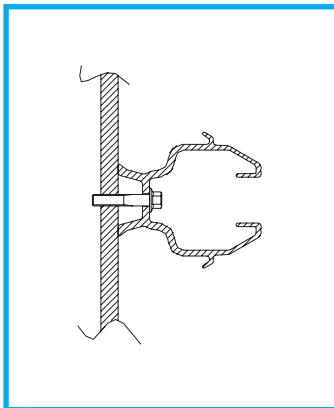

A. Steel

Secure the guide rails with self-threading screws.

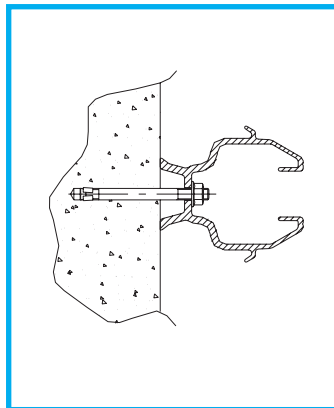

B. Concrete

Drill holes in the concrete for expansion screws with which to secure the guide rails.

Screw data

	S800	S1000
Screw dimension of	M8	M10
Strength class grade	8.8	8.8
Steel mounting surface	$t \geq 6$	$t \geq 8$
Concrete mounting surface	$t \geq 90$	$t \geq 100$

See also dimensional drawing page 17, 18, 19, 20, 21, 22.

System 800

Self-supporting version

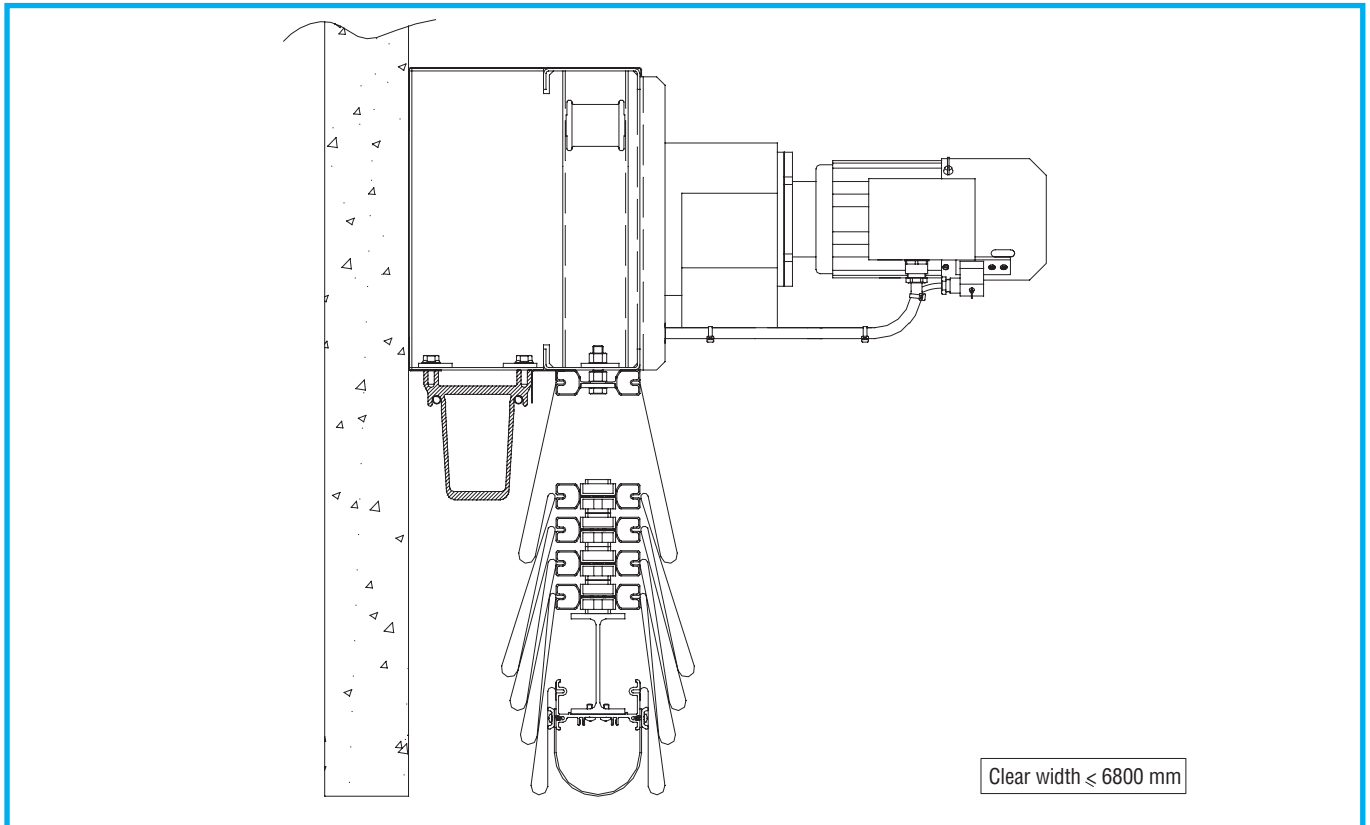

We can supply a self-supporting door if there is no suitable mounting surface over the door opening. A supporting beam, fixed underneath the header box, transfers the load via the jambs of the door to the building. The jambs are dimensioned to take up forces from the header box but must, however, be secured to the building.

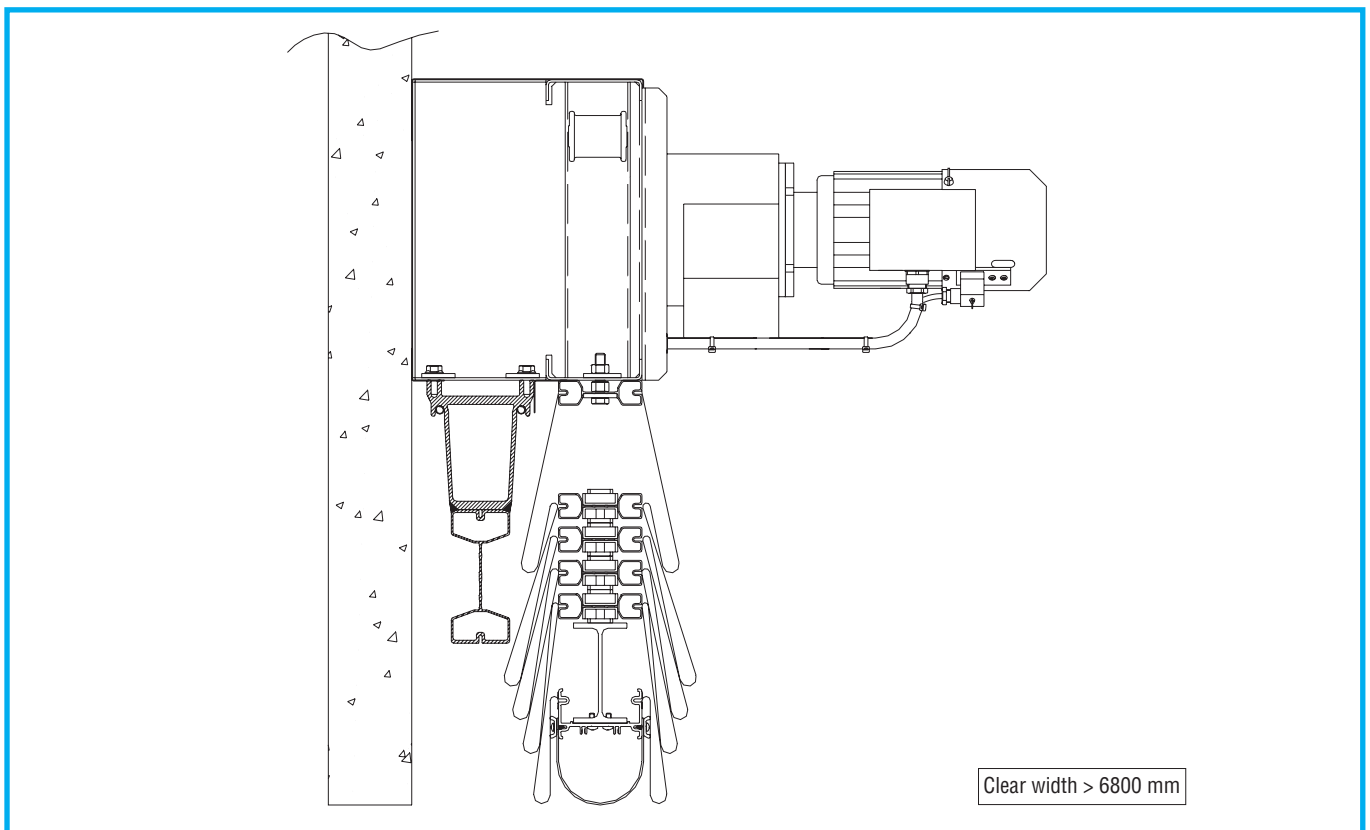

Jambs

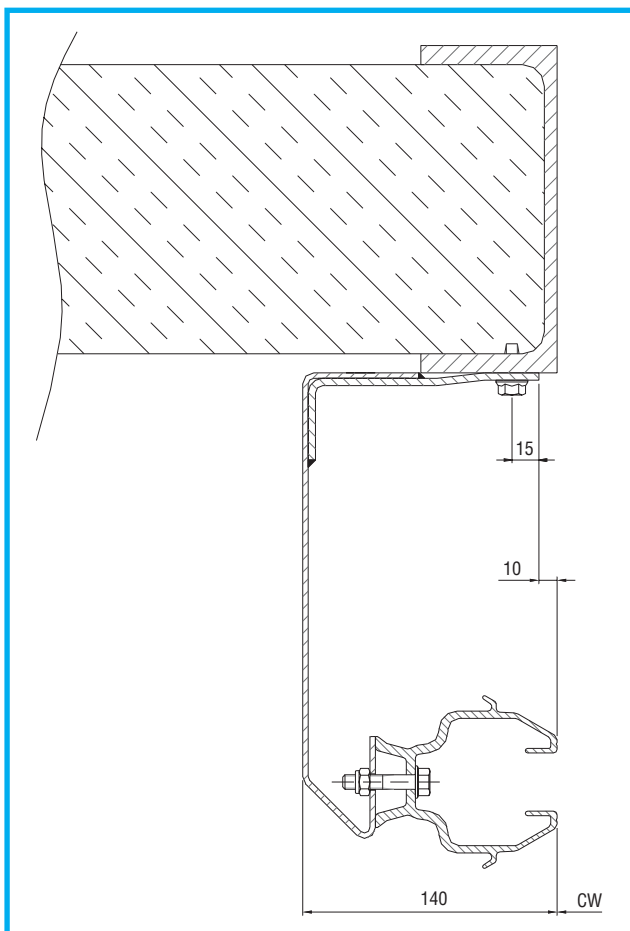
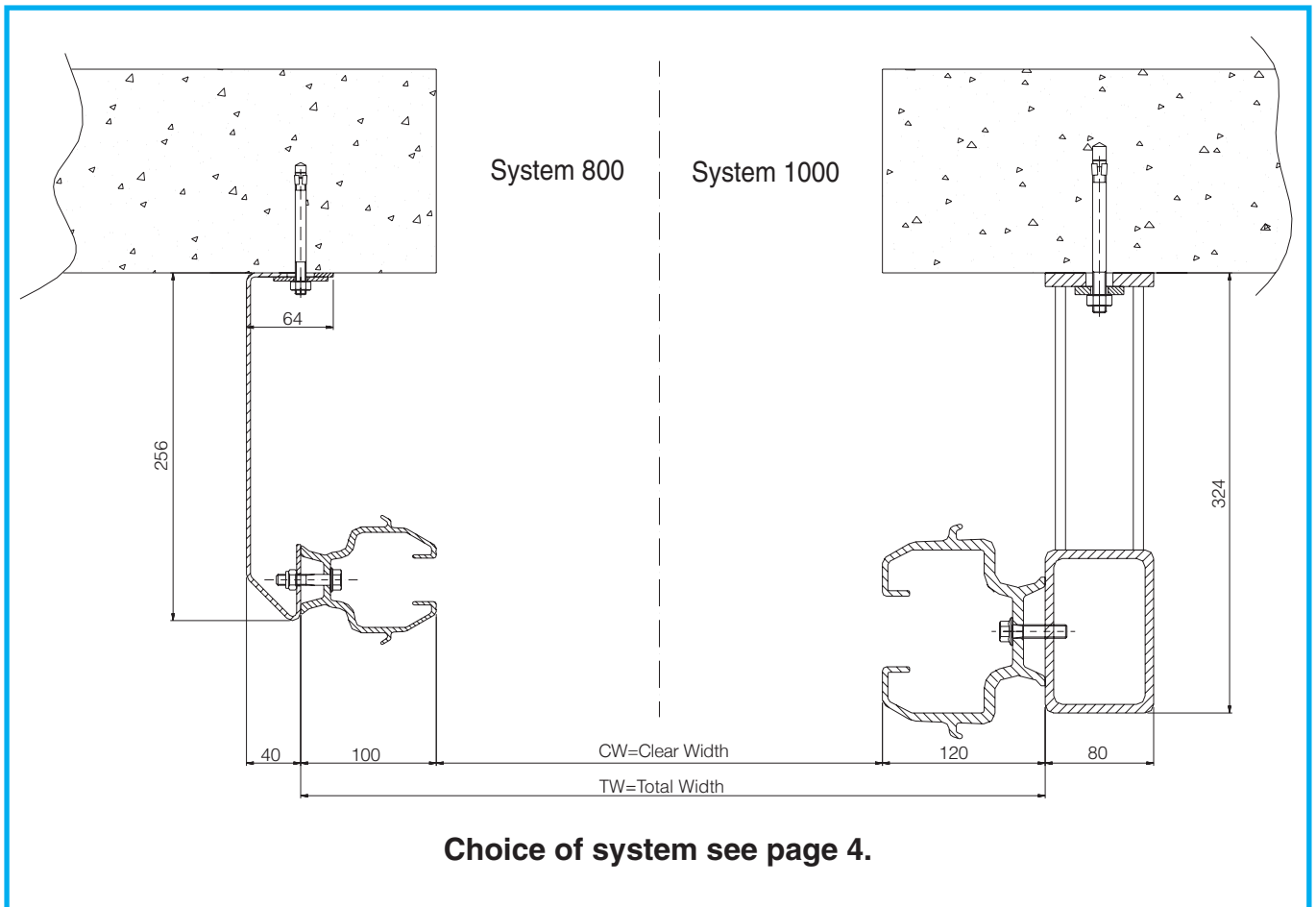

For openings where posts for fixing the guide rails are not available, we provide stable jambs. The ways of mounting the jambs are the same as those used for the guide rails, with about 1 metre spacing. Insulation of the jambs is possible, but material for the purpose is not included in the delivery.

The jambs are made by steel, painted black.

An extension jamb is available for S 800 making it possible to reach all the way to existing steel and still obtain a shielded location for the guide rails.

Enclosing the header box

Enclosed motor side

The door is delivered as standard with the motor side enclosed. Components that need access for inspection are located at the ends of the header box behind hatches. The rest of the header box has a fixed steel sheet enclosure.

Enclosed “non-motor side” (extra)

For fitting in a door opening with the geared motor facing inwards, the “non-motor side” should be fitted with a fixed sheet-metal cover. Inspection is made, as always, from the motor side, in this case from inside the building. Insulation of the header box is possible (optional).

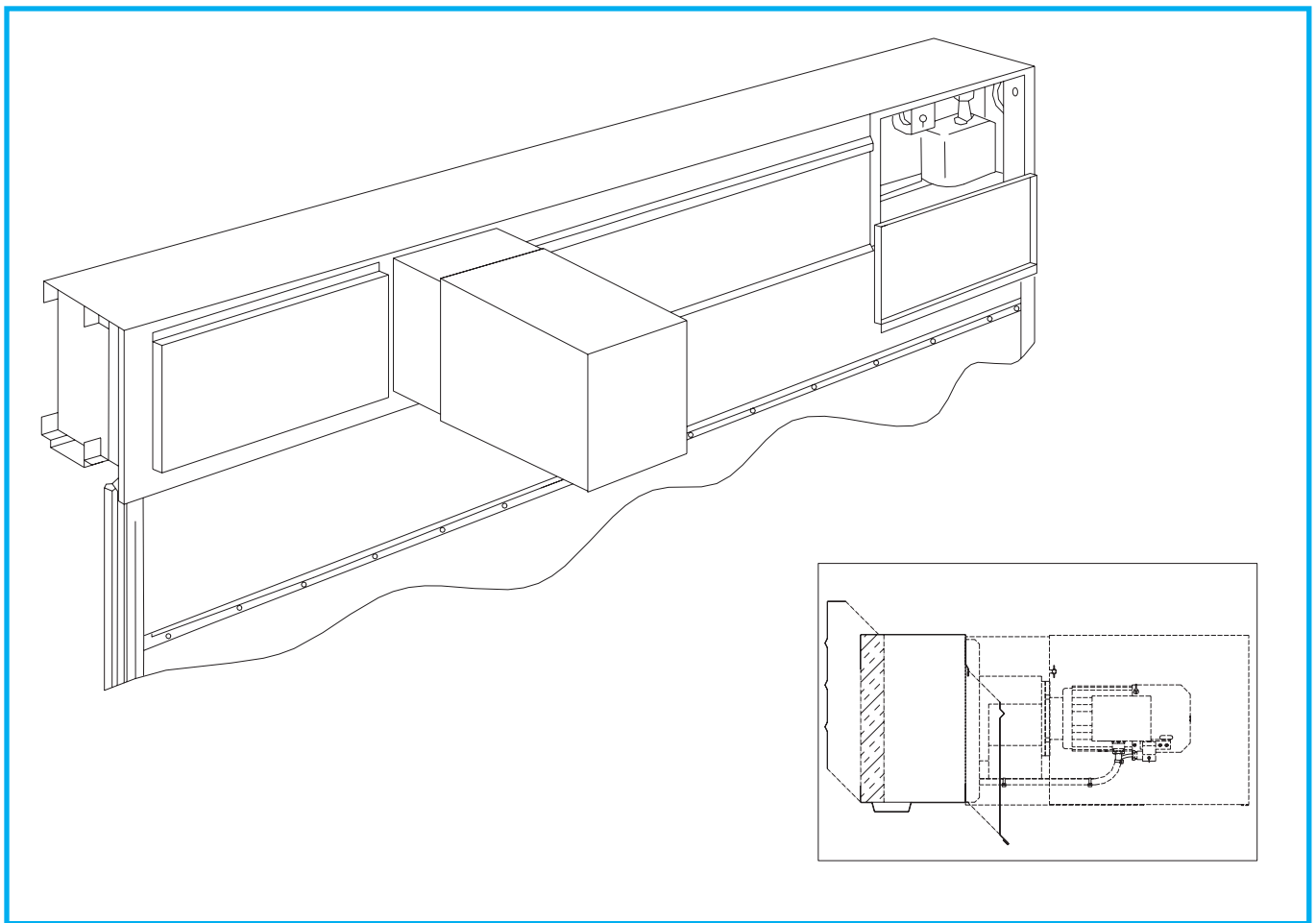

Protective casing over motor (extra)

For outdoor fitting, or in a dirty environment, the motor should be fully protected. The protective casing is made of powder coated steel sheet.

The casing is provided with a hatch to facilitate easy access to the motor for possible manual emergency operation. The entire cover can be removed. Existing doors can also be complemented with a protective casing.

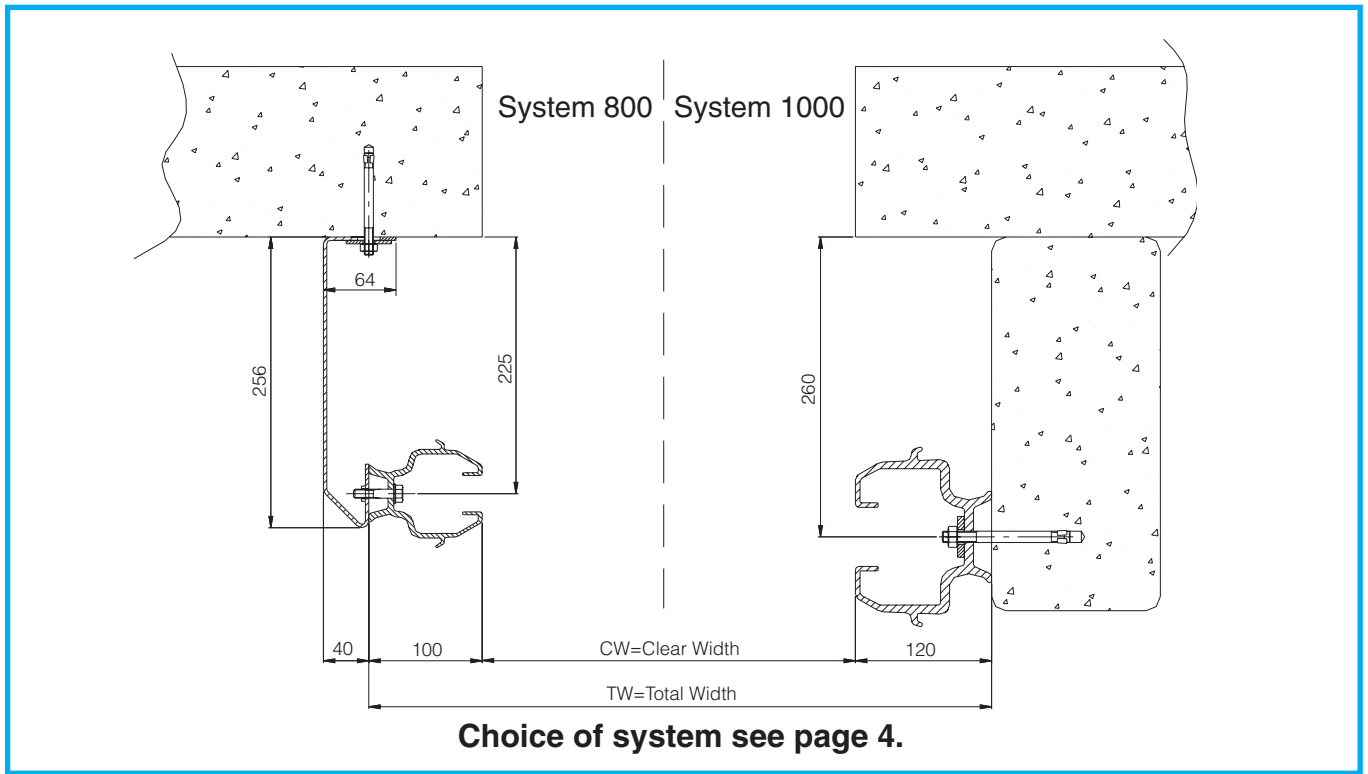

Space requirements for System 800

Space requirements are the same for the self-supporting version.

$$TH = 1.05 \times CH + 840$$

$$CH = \frac{TH - 840}{1.05}$$

Space requirements for System 1000

Megadoor calculates the total height. Please get in touch with our nearest office for exact data.

Space requirements for fabric and inspection

The dotted line shows the space required for the fabric when the door is in motion.

Limiting surfaces must be smooth. The space between the wall and the fabric must be free from bolts, electric cables, etc.

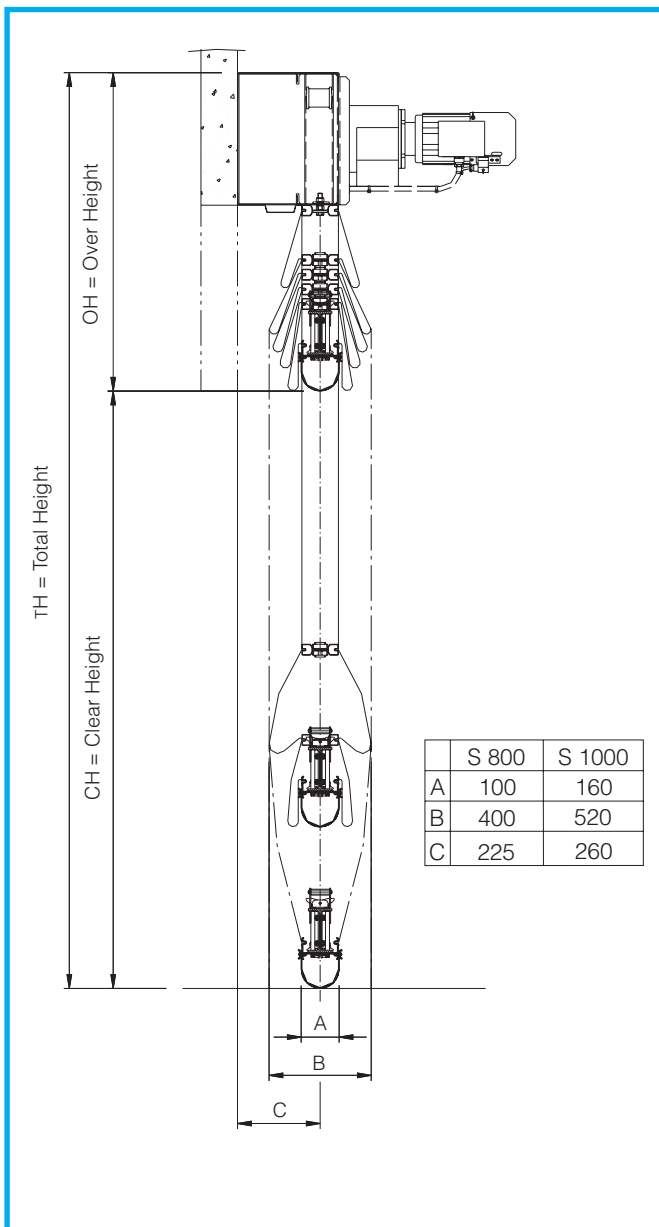

Space requirements for inspection

S 800 1-Motor

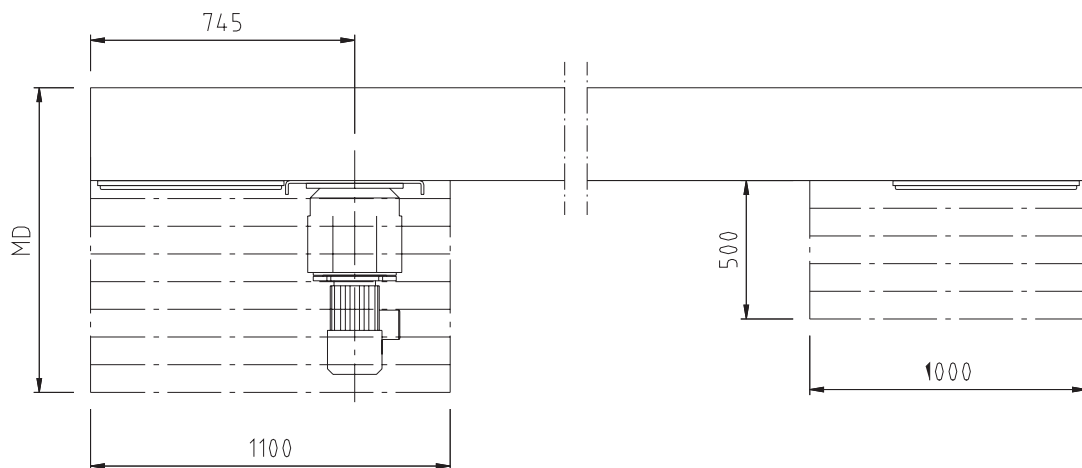

MD = motor depth. Depending on motor size.

System 800: MD = 750–1100 mm (+ 200 mm for hand crank).

System 1000: MD = 1000–1200 mm (+ 200 mm for hand crank).

S 1000 1-Motor

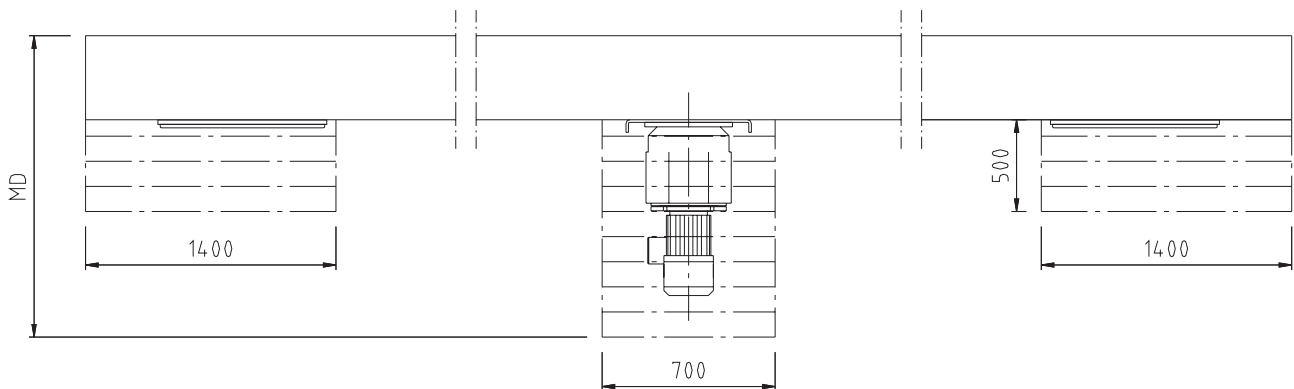

S 1000 2-Motors

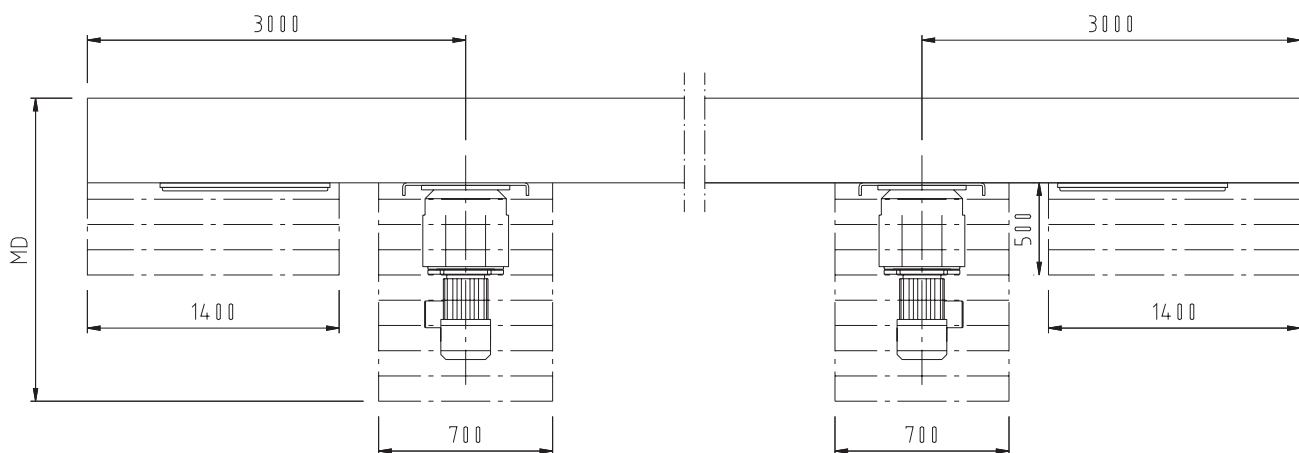

Location of the control cabinet

Casing of the control cabinet complies with protection classification IP 65. This means that the cabinet may be located in a harsh environment.

However, since the cabinet will have to be opened occasionally, eg, to replace a fuse, and may thus allow moisture to enter, it is advisable to locate the cabinet away from any strongly corrosive atmosphere.

The cabinet should not be placed immediately adjacent to the door, if there is a risk of severe condensation when the door is opened. In such cases it is more suitable to place the control device close to the door and the control cabinet in a well-protected location. If this is not possible, there is a stainless steel alternative.

The following space requirements incl brackets (w x h x d) may be of assistance in deciding where to place the control cabinet, any additional cables or any additional safety switch for the power supply:

Door type	Motors	Door control	Cabinet size (carbon steel or stainless)	Space requirements
S 800 + S1000	1	0451	400 x 500 x 200	600 x 700 x 220
S 800 Increased opening speed	1	0451	400 x 500 x 200	600 x 700 x 220
S 1000	2	0452	600 x 600 x 200	800 x 800 x 220

PLC

The control cabinet contains a PLC for the setting of timers and automatic functions. The PLC is programmed by Megadoor before delivery and also configured. The menu gives information such as:

- Days of operation and number of door openings from the start and since last service occasion
- Actual settings
- Diagnostic information

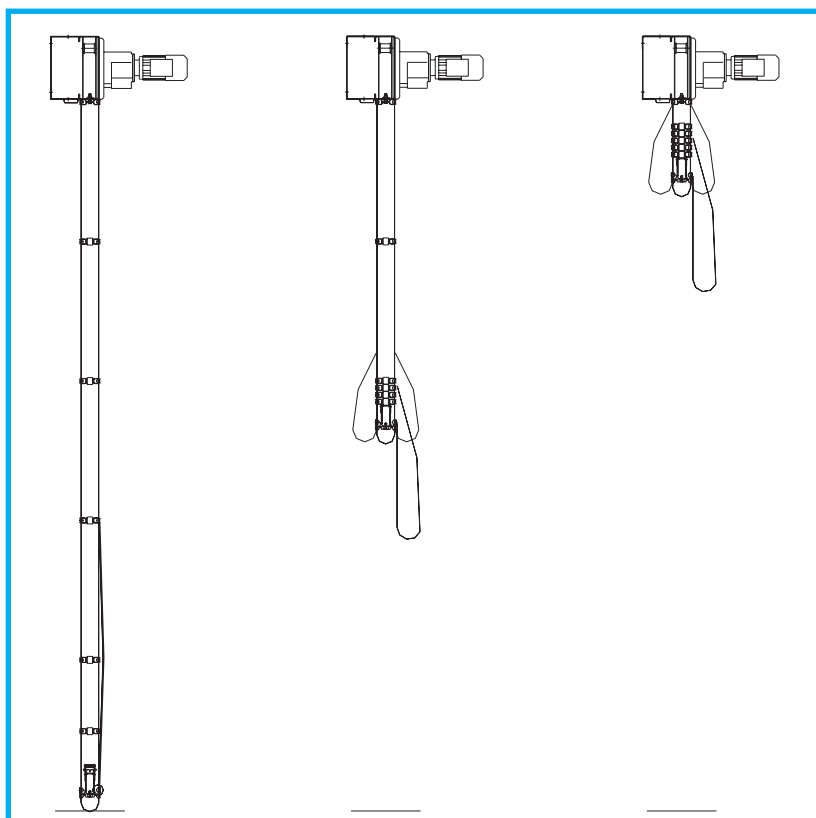
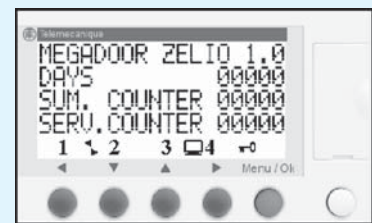

Flex-Away

To reduce the risk of collision S 800 / S 1000 can be fitted with a safety device, Flex-Away (Swedish Patent 506664).

During the opening phase, Flex-Away gives an extra margin to harder parts of the door leaf. It thus provides an effective shield against damage by collision by reducing the risk of misjudging the position of the door.

If Flex-Away is collided with there will be no need for resetting or repairs as is the case with conventional alternatives.

Megadoor and the environment

The following recycling options are available, depending on the material involved, for discarded Megadoor components:

Steel

- Sheet	Recycling
- Rolled sections	Recycling
- Machined components	Recycling

Aluminium

- Extruded sections	Recycling
---------------------	-----------

Plastic/Elastomers

- Injection-moulded components (Polyoxymethylene)	Incineration/Recycling
- Fabric (Polyvinyl chloride/Polyester)	Incineration/Re-use/Recycling
- Extruded sections (Ethylene-propylene rubber)	Incineration/Recycling
- Fabric (Ethylene-propylene rubber)	Incineration/Recycling

Definition of above terms:

Incineration: The energy content can be utilised without exceeding permitted emission limits.

Re-use: The material can, after processing, be used again in an identical product.

Recycling: The material can, after processing, be used in other products.

Our customer number at REPA (Green Dot): 5560599523

Environmental durability of S 800 and S 1000

In their normal versions the doors are designed for operation in environments within the limits stated below. For requirements outside these limits we are often able to oblige by modifying or complementing the door.

Environment criterion	Normal value
Temperature	-35°C to +70°C
Atmospheric humidity	Below dew point
Presence of particles	<1000 µg/m ³ air
Mechanical load, blasting	Not directly aimed
Differential pressure, closed door	Temporary 0.7 - 1.6 kPa (EN 12424 class 3-5) depending on door type
Wind speed, door in motion	<20 m/s
Galvanic load	No salt present in condensate
Acidity	Condensate at 5 < pH < 9
Explosive fumes or dust	No occurrence

MEGADOOR™ S 800

FITTING AGAINST WALL

QUOTATION NO:.....	DATE.....
ORDER NO:.....	SIGNATURE.....
CODE:.....	
CW=.....	TS=.....
CH=.....	TH=.....
OH=.....	MD=.....

 = Fitting surface

w	
h	See page 15
d	
t	See page 8 & 9

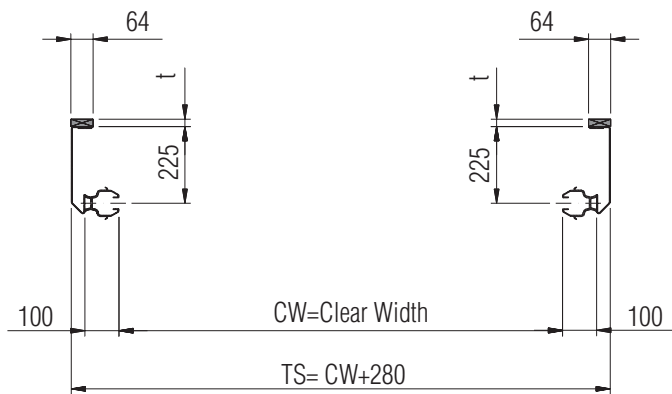
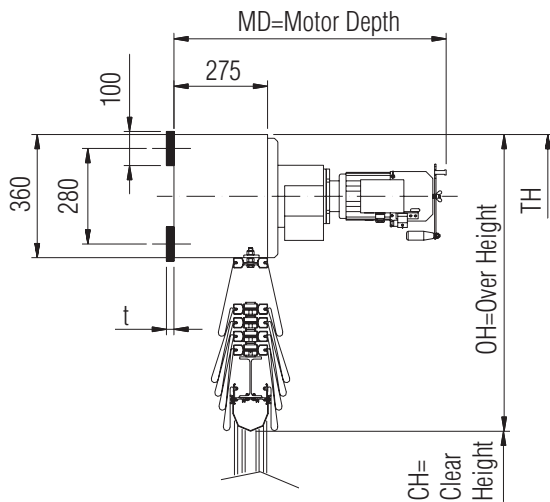
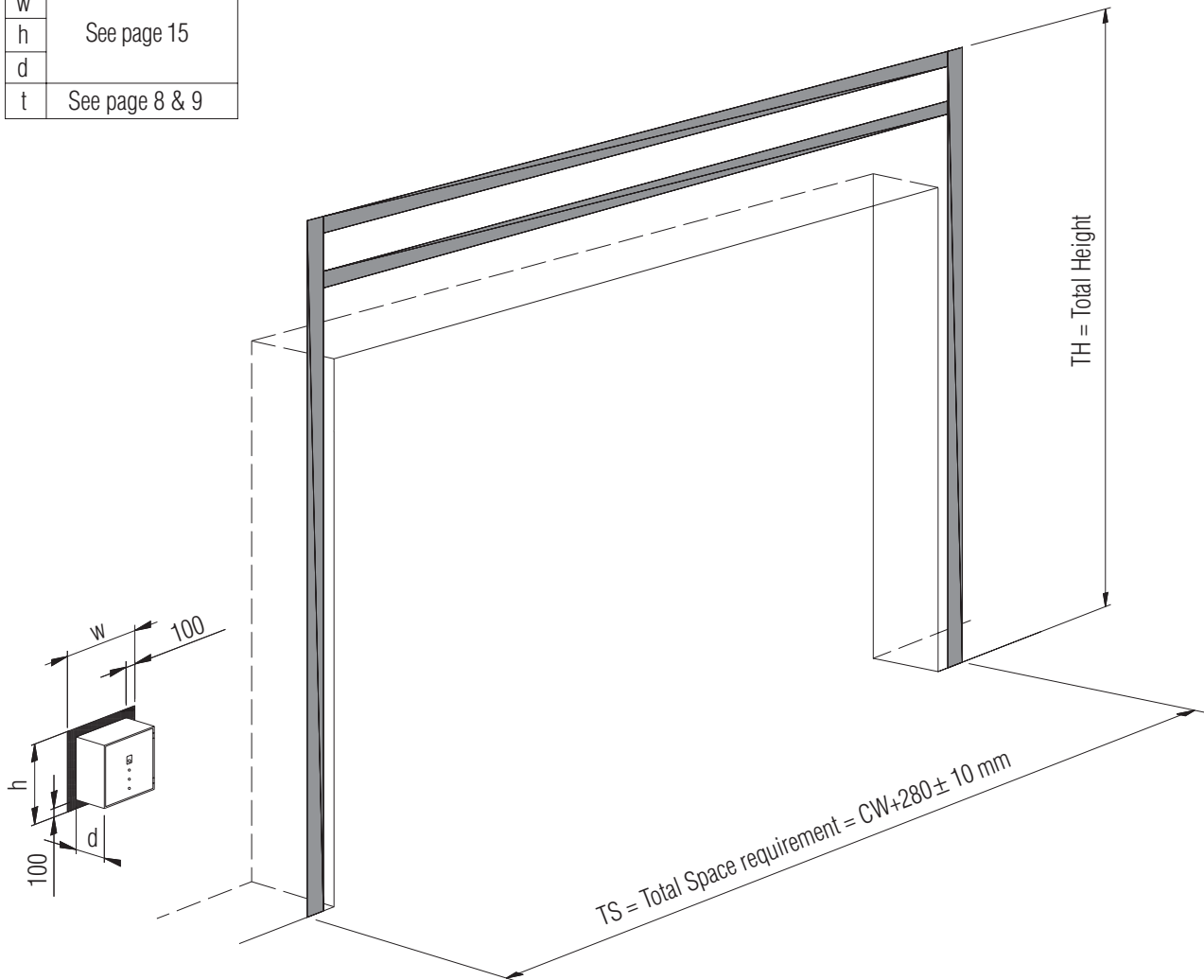

Mounting surfaces must be parallel and deviate max 5 mm from the vertical and max 2 mm/m in the inward/outward direction from the vertical.



MEGADOOR™ S 800

FITTING AGAINST WALL BETWEEN COLUMNS

QUOTATION NO:.....	DATE.....
ORDER NO:.....	SIGNATURE.....
CODE:.....	
CW=.....	TW=.....
CH=.....	TH=.....
OH=.....	MD=.....

 = Fitting surface

b	
h	See page 15
d	
t	See page 8 & 9

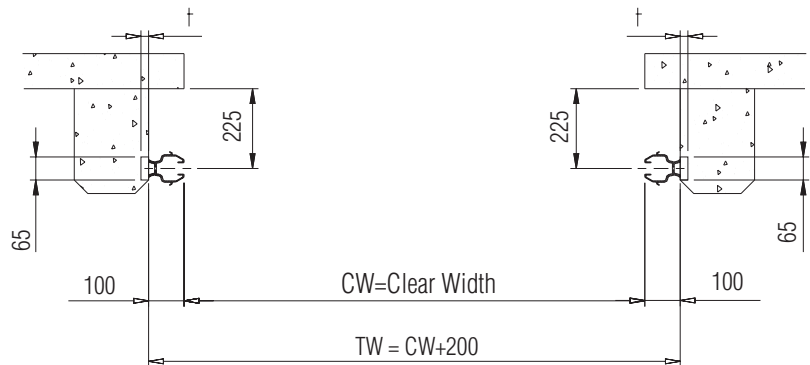
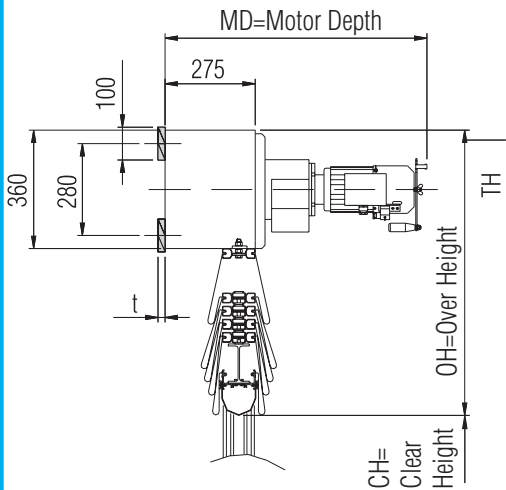
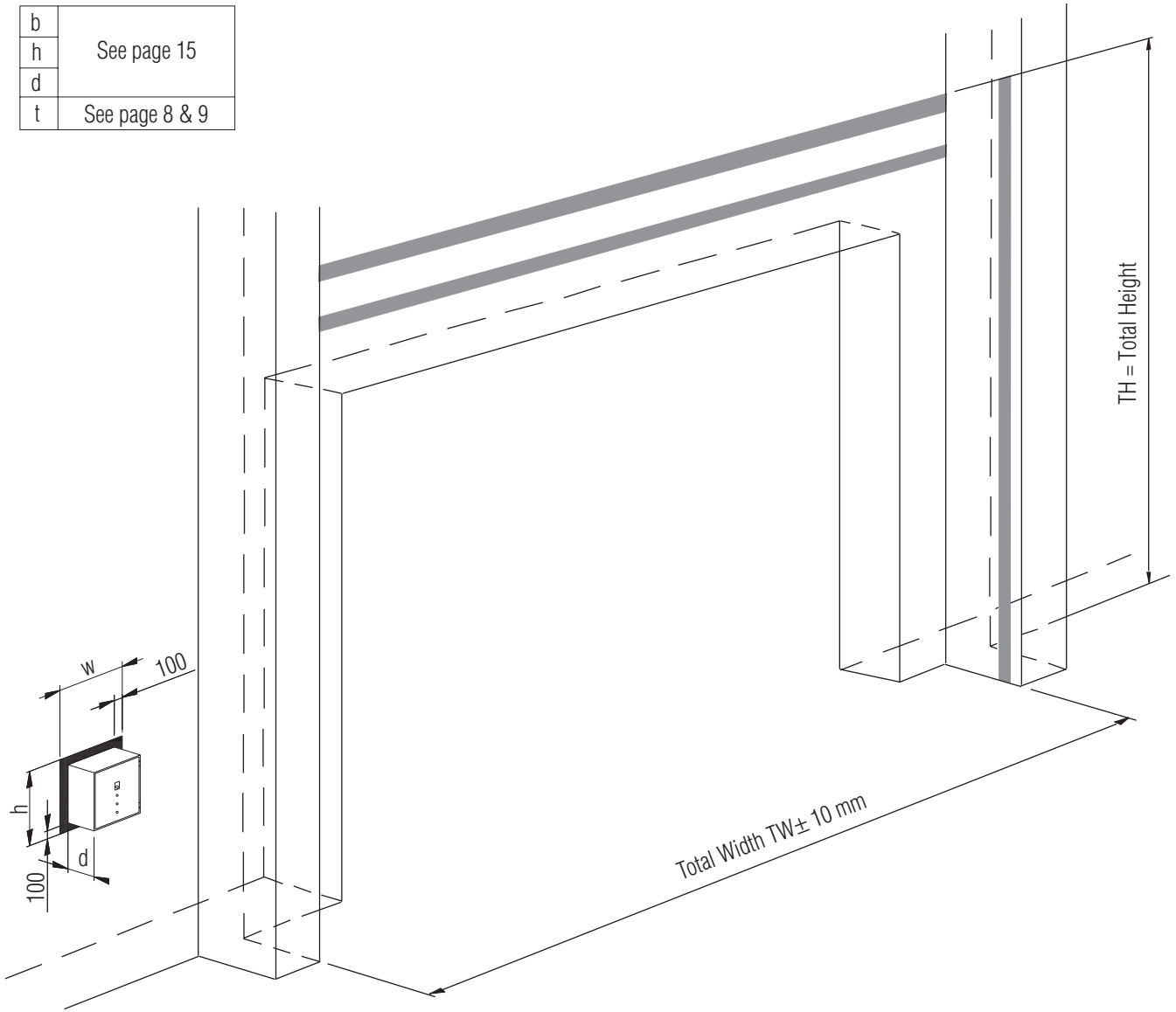

Mounting surfaces must be parallel and deviate max 5 mm from the vertical and max 2 mm/m in the inward/outward direction from the vertical.

MEGADOOR™ S 800

FITTING WITH SELF-SUPPORTING HEADER BOX

QUOTATION NO:.....	DATE
ORDER NO:.....	SIGNATURE
CODE:.....	
CW=.....	TS=.....
CH=.....	TH=.....
OH=.....	MD=.....

 = Fitting surface

w	See page 15
h	
d	
t	See page 8 & 9

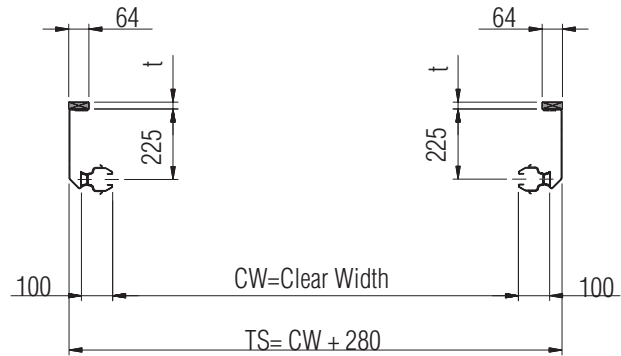
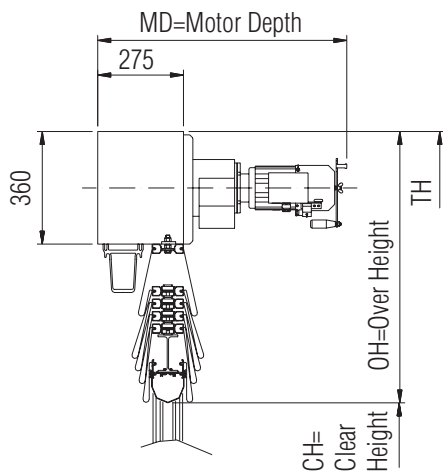
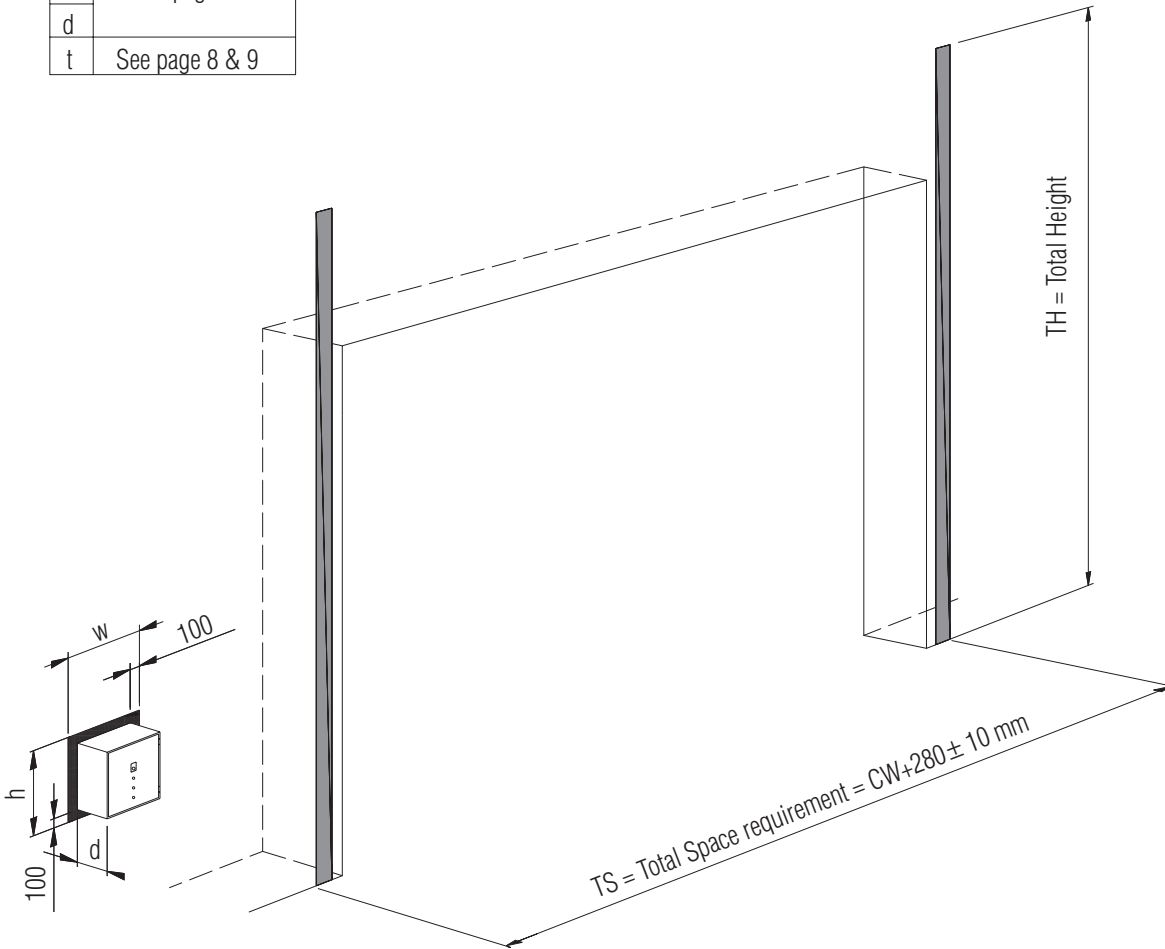

Mounting surfaces must be parallel and deviate max 5 mm from the vertical and max 2 mm/m in the inward/outward direction from the vertical.

MEGADOOR™ S 800

FITTING IN DOOR OPENING

QUOTATION NO:.....	DATE
ORDER NO:.....	SIGNATURE
CODE:.....	
CW=.....	TW=.....
CH=.....	TH=.....
OH=.....	MD=.....

 = Fitting surface

w	
h	See page 15
d	
t	See page 8 & 9

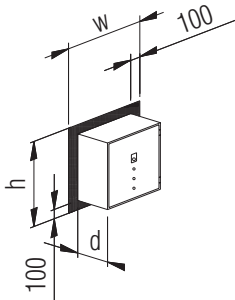
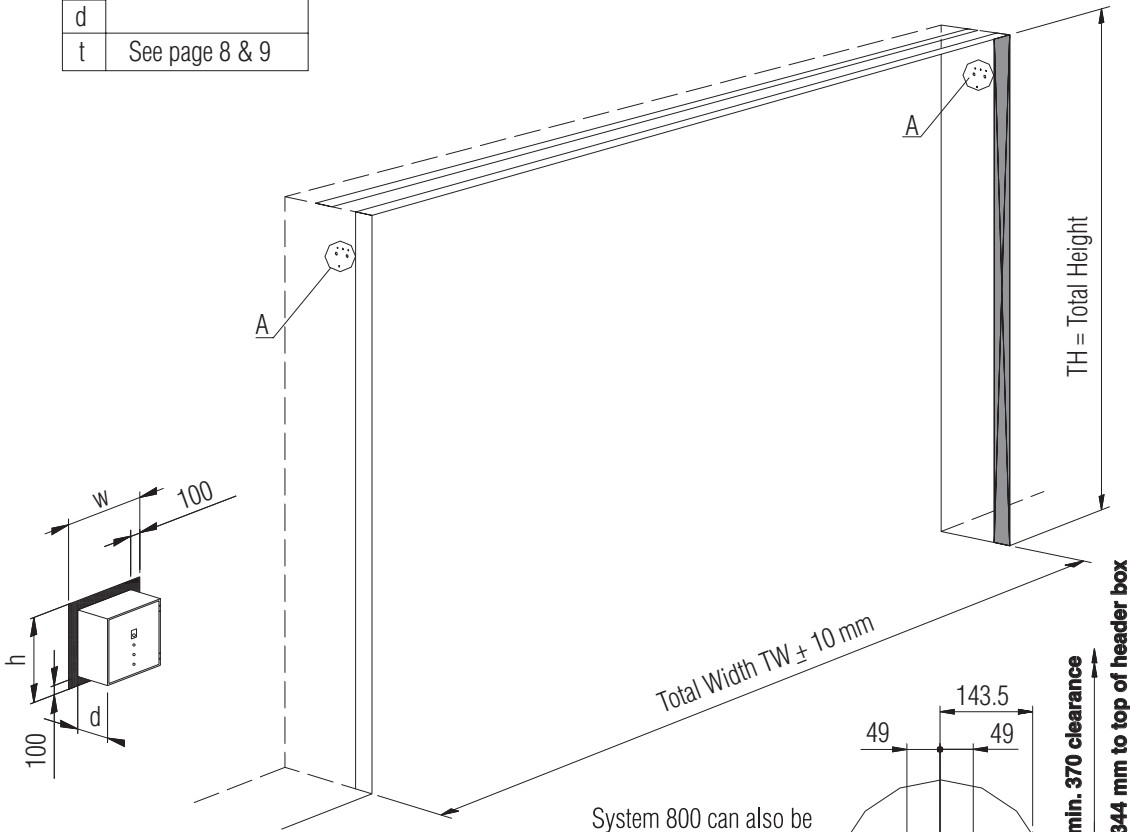

System 800 can also be combined with a self-supporting header box. The upper fixing surfaces are then replaced by surfaces for securing brackets.

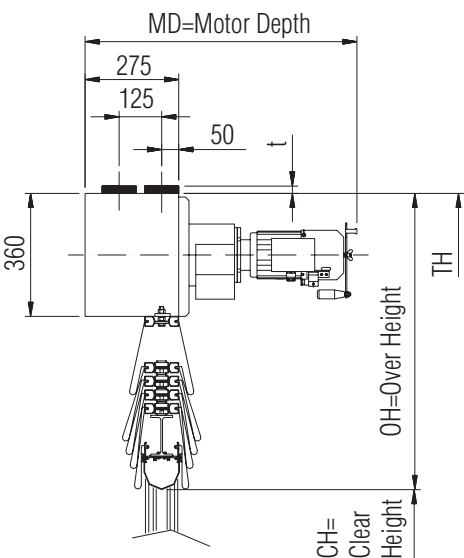
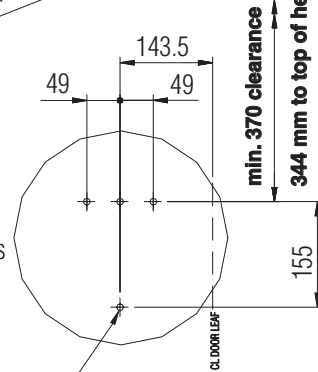

For concrete:
Hole $\varnothing 8 \times 65(4x)$

For steel:
X= 4-6.5 mm Hole $\varnothing 9.25(4x)$
X= 6.5-10 mm Hole $\varnothing 9.30(4x)$
X= 10-15 mm Hole $\varnothing 9.40(4x)$

Detail A

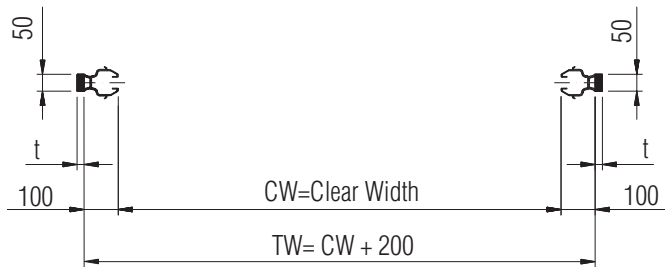

Mounting surfaces must be parallel and deviate max 5 mm from the vertical and max 2 mm/m in the inward/outward direction from the vertical.

MEGADOOR™ S 1000

FITTING AGAINST WALL

QUOTATION NO:.....	DATE
ORDER NO:.....	SIGNATURE
CODE:.....	
CW=.....	TS=.....
CH=.....	TH=.....
OH=.....	MD=.....

 = Fitting surface

w	See page 15
h	See page 15
d	See page 8 & 9
t	See page 8 & 9

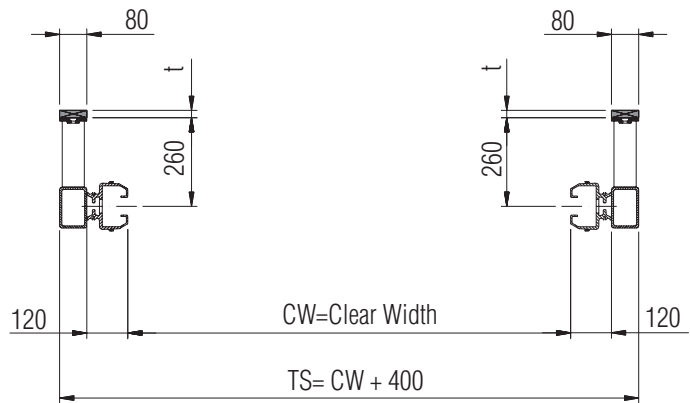
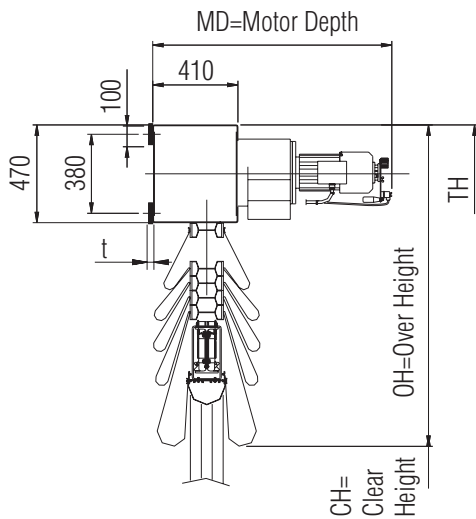
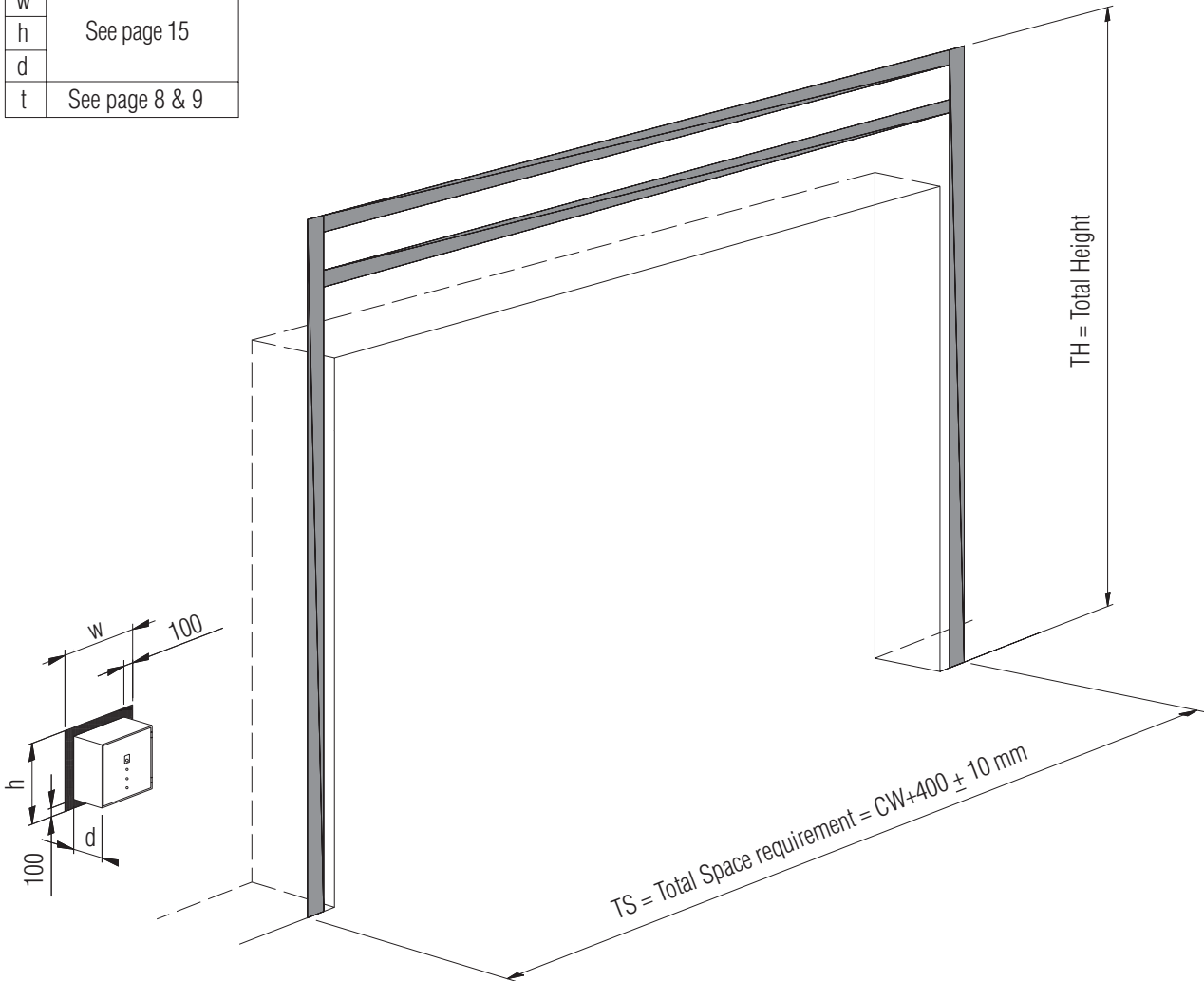

Mounting surfaces must be parallel and deviate max 5 mm from the vertical and max 2 mm/m in the inward/outward direction from the vertical.



MEGADOOR™ S 1000

FITTING IN DOOR OPENING

QUOTATION NO:.....	DATE.....
ORDER NO:.....	
CODE:.....	SIGNATURE.....
CW=.....	TW=.....
CH=.....	TH=.....
OH=.....	MD=.....

 = Fitting surface

w	See page 15
h	
d	
t	See page 8 & 9

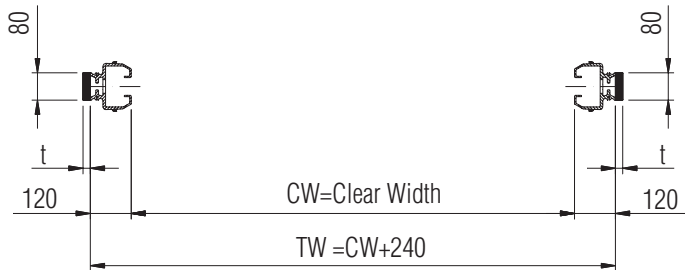
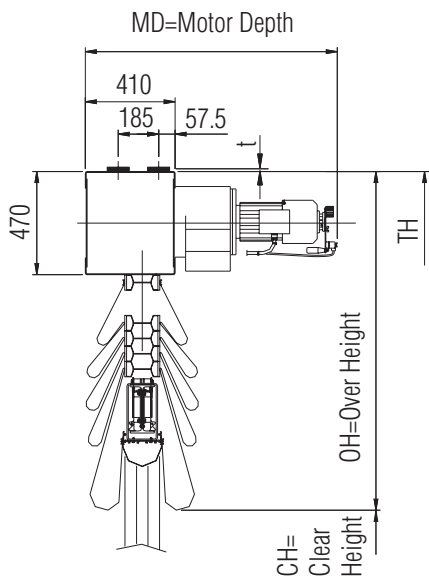
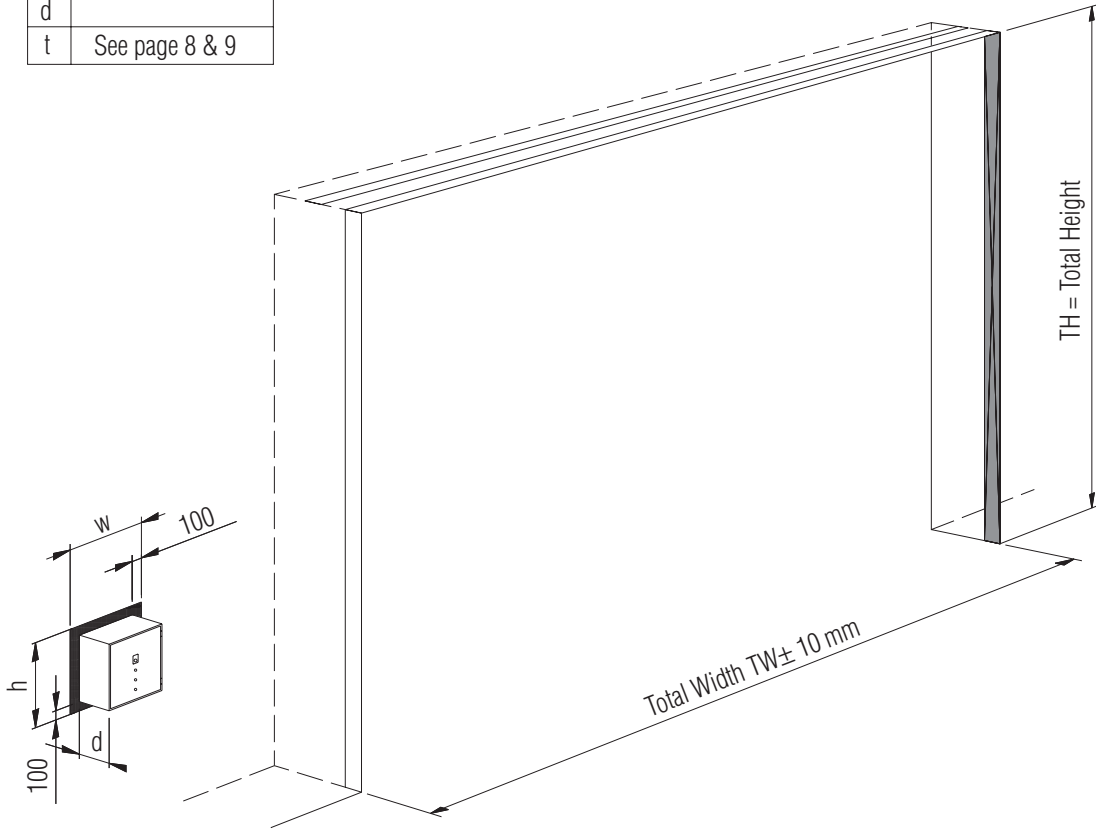

Mounting surfaces must be parallel and deviate max 5 mm from the vertical and max 2 mm/m in the inward/outward direction from the vertical.

Megadoor door systems:

- System 800: width \leq 8.7 m, height \leq 12 m
- System 1000: width \leq 16 m, height \leq 20 m
- System 1500/Special Doors: virtually no size limitations



Megadoor AB

Servicegatan 6, SE-931 76 Skellefteå, Sweden

Tel: +4691083700, Fax +4691083709

e-mail: sales@megadoor.se

www.megadoor.se

Megadoor is a company within Crawford Group AB,
for local representation, see:

www.crawforddoor.com

Megadoor AB reserve the right to make technical changes

