



## Crawford Monitoring System – Security pack

### How can you improve active security at your facility?

Closing and locking doors is an obvious answer, but checking this manually is time consuming in a busy facility. With a Crawford Monitoring System you can automatically ensure that all doors are closed and locked when they need to be.

### How does it work?

#### 1. Each bay is connected via a serial bus cable to a computer

Crawford products with i-supervision or 950 docking control units can be connected directly to the server via a connection box.

Products with other control boxes are connected via a D2G communication unit.

#### 2. Sensor to detect the door position and lock status is connected to the control units

The doors can also be equipped with electrical locks and different access options (e.g. Card reader, Code, RFID Gate).

You can also remotely activate all doors and locks, and get a real-time overview of the security status. All bays can be connected to the Monitoring System's server giving you the opportunity to supervise, monitor and report on a wide variety of aspects in your facility. Your facility is more secure and you can prove it.

#### 3. On the computer we install a web based server software that will monitor and control the activity at the bay



The server can be connected to Intranet or Internet. The software can also be installed, if required on a virtual server.

The access of the site is protected by a login with username and password giving the possibility to have users with different access rights.

The user has an overall view of the facility, giving him real time, the security status. With the detailed view, the user has control on the activity at the door. He knows what door is open or closed, locked and unlocked.

# Crawford Monitoring System – Security pack



The system can also be upgraded with:

- A function to remote steer the locks
- The remote opening & closing of the door function
- An interlocking function so that the opening of the door is not possible if no truck is at the bay
- An over ruling function to open the door even if no truck is at the bay
- A function to know the dock leveller position and avoid an opening between a closed door and a leveller in low position.

## 4. Integration of Camera view



The system can be easily upgraded and we can also deliver and integrate live camera view on the activity.

## 5. Activity Reports

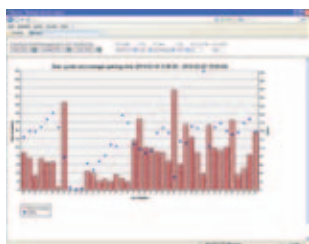

As we monitor all activities at the bay we can generate statistical report on the usage of the facility e.g: average time the door is opened, average time dock at the bay. The reports are available in Microsoft excel format.

## 6. Requirements

### Processor

Min Pentium D 3 GHz.

### RAM

Min 1 GB.

### Hard disk

10 GB of free space.  
(the logging will require 5-30MB/Month).

### Printer

Microsoft Windows compatible.

### Interface

To connect the our BUS-system a free RS232 or USB interface should be provided.

### Software requirements

Windows 2000, Windows XP Professional, Windows 2000 Server, Windows 2003 Server R1 and R2, Windows 2008 Server, including Microsoft .NET 1.1.

## 8. Kabelspecifikation UNITRONIC® BUS PA

Överföringsteknik RS 485

Ledningar av tunna koppartrådar, partvinnade, med skärm av koppartrådar

Temperaturintervall: fastmonterad –30°C till +60°C

Ledningsresistans: max. 44 Ohm/km

Karakteristisk impedans: (slinga) 100 +/- 20 Ohm

Par/kärna och diameter i mm: 1 x 2 x 1,0 Ø

## Crawford kan göra mycket mer

Våra medarbetare är experter på att ge dig rätt råd för att öka säkerheten vid din anläggning.

## About Crawford

Crawford is a leading ASSA ABLOY brand focusing on automated entrance solutions for efficient movement of vehicles and goods. With a complete portfolio of door and docking solutions, an extensive service offer and professional advice, we help customers ensure convenient, safe, secure and energy saving operations around-the-clock.

[www.crawfordsolutions.com](http://www.crawfordsolutions.com)





## To function properly all of the time, your facility needs pro-active maintenance

The Crawford Monitoring System gives you real-time service status for all of your door and docking equipment. If an error code occurs, the Crawford service organisation is automatically notified, and will respond quickly. Other maintenance information can easily be integrated, further reducing your overall costs.

All bays are connected to the Monitoring System's server giving you the opportunity to supervise, monitor and report on a wide variety of aspects in your facility. Your facility is better maintained and you can prove it.

### How does it work?

#### 1. Each bay is connected via a serial bus cable to a computer

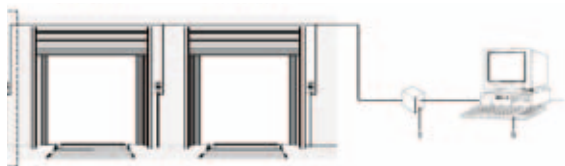

Crawford products with i-supervision or 950 docking control units can be connected directly to the server via a connection box.

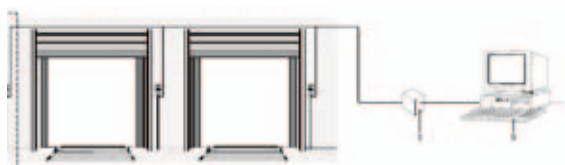

Products with other control boxes are connected via a D2G communication unit.

#### 2. On the computer we install a web based server software that will monitor and control the activity at the bay



The server can be connected to Intranet or Internet. The software can also be installed, if required, on a virtual server.

The access of the site is protected by a login with username and password giving the possibility to have users with different access rights.

The user has an overview of the facility and knows the status of each bay and the alarm status. He can reserve a bay if necessary for maintenance or if an accident has happened avoiding to disorganize the production flow.

Via a detailed view on the bay status, the user also has access to the following information:

- Door opened/closed
- Leveller in operation
- Error Codes (Crawford products)
- Number of cycles

# Crawford Monitoring System – Facility Management

## 4. Automatic information transfer to Crawford Service

If you have a Crawford Service Agreement, we can automatically alert and send a maintenance message to our service organisation.

## 5. Connection to 3<sup>rd</sup> party Facility Management Systems



Crawford Monitoring System is based on an open standard OPC server and is therefore easy to connect and transfer real time information to a 3<sup>rd</sup> party System.

## 6. Report and statistics



As we monitor all activities at the bay we can generate statistical report on the usage of the facility providing valuable information for maintenance planning.

## 7. Requirements

### Processor

Min Pentium D 3 GHz.

### RAM

Min 1 GB.

### Hard disk

10 GB of free space.

(the logging will require 5-30MB/Month).

### Printer

Microsoft Windows compatible.

### Interface

To connect the our BUS-system a free RS232 or USB interface should be provided.

### Software requirements

Windows 2000, Windows XP Professional, Windows 2000 Server, Windows 2003 Server R1 and R2, Windows 2008 Server, including Microsoft .NET 1.1.

## 8. Cable specification UNITRONIC® BUS PA

Transmission technology RS 485

Fine-wire strand of plain copper wires, cores twisted to pairs screening braid of copper wires

Temperature range: permanently mounted –30°C to +60°C

Conductor resistance: max. 44 Ohm/km

Characteristic Impedance: (loop) 100 +/- 20 Ohm

Pairs/cores and diameter in mm: 1 x 2 x 1,0 Ø

## Crawford can do much more

Our people are experts in giving you the right advice to reduce your overall maintenance costs.

## About Crawford

Crawford is a leading ASSA ABLOY brand focusing on automated entrance solutions for efficient movement of vehicles and goods. With a complete portfolio of door and docking solutions, an extensive service offer and professional advice, we help customers ensure convenient, safe, secure and energy saving operations around-the-clock.

[www.crawfordsolutions.com](http://www.crawfordsolutions.com)





## Crawford Monitoring System – Navigation & Dock Management

### How can you reduce congestion at the dock area?

A good way to increase throughput and thereby efficiency at your logistics facility is to reduce the amount of time when no truck – or the wrong truck – is at a loading bay. A Crawford Monitoring System can tell you – in real-time – which bays are occupied or free, and for how long. It enables you to reserve bays for docking activities and inform drivers via SMS.

Since it incorporates information from cameras and other inputs (RFID, card readers, etc.), the system stays updated in real-time. All bays can be connected to the Monitoring System's server giving you the opportunity to supervise, monitor and report on a wide variety of aspects in your facility. You are more efficient and you can prove it.

### How does it work?

#### 1. Each bay is connected via a serial bus cable to a computer

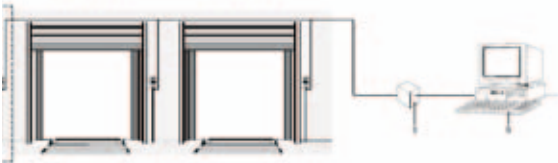

Crawford products with i-supervision or 950 docking control units can be connected directly to the server via a connection box.

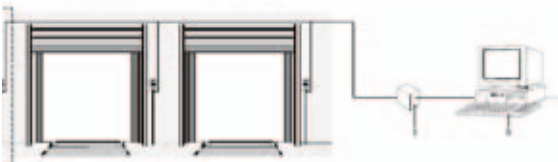

Products with other control boxes are connected via a D2G communication unit.

#### 2. At the bay we install a sensor that will detect if the truck is docked

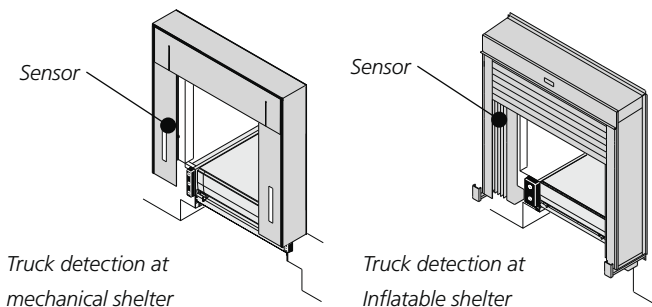

#### 3. On the computer we install a web based server software that will monitor and control the activity at the bay



The server can be connected to Intranet or Internet. The software can also be installed, if required on a virtual server.

The access of the site is protected by a login with username and password giving the possibility to have users with different access rights.

The user has an overall view, like in a control tower, of the facility giving him complete control on what is happening at the docks, what bay is free or occupied. With the detailed view, the user has control on the activity at the bay. He knows what dock is free or occupied and knows when trucks arrive or leave. Bays can be reserved for dedicated trucks or maintenance.

# Crawford Monitoring System – Navigation & Dock Management



The system can also be upgraded with:

- The remote opening & closing of the door function.
- The SMS function so that the user can send, via the system, an SMS message to the truck driver with information: Go to bay Nr, Go to Parking, Contact transport plan or any message of your choice and that in several languages.
- A Connection to your RFID Gate to inform if wrong goods are loaded in a truck.

## 4. Integration of Camera view

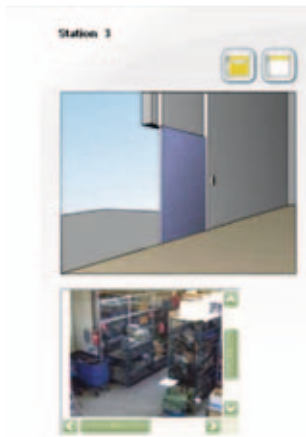

The system can be easily upgraded and we can also deliver and integrate live camera view on the bay activity.

## 5. Connection to ERP – WMS - TMS Systems



Crawford Monitoring System is based on an open standard OPC server and is therefore easy to connect and transfer real time information to a 3<sup>rd</sup> party System.

## 6. Activity Reports



As we monitor all activities at the bay we can generate statistical report on the usage of the facility e.g: average time the door is opened, average time dock at the bay. The reports are available in Microsoft excel format.

## 7. Requirements

### Processor

Min Pentium D 3 GHz.

### RAM

Min 1 GB.

### Hard disk

10 GB of free space.

(the logging will require 5-30MB/Month).

### Printer

Microsoft Windows compatible.

### Interface

To connect the our BUS-system a free RS232 or USB interface should be provided.

### Software requirements

Windows 2000, Windows XP Professional, Windows 2000 Server, Windows 2003 Server R1 and R2, Windows 2008 Server, including Microsoft .NET 1.1.

## 8. Cable specification UNITRONIC® BUS PA

Transmission technology RS 485

Fine-wire strand of plain copper wires, cores twisted to pairs screening braid of copper wires

Temperature range: permanently mounted –30°C to +60°C

Conductor resistance: max. 44 Ohm/km

Characteristic Impedance: (loop) 100 +/- 20 Ohm

Pairs/cores and diameter in mm: 1 x 2 x 1,0 Ø

## Crawford can do much more

Our people are experts in giving you the right advice to improve your dock management. Crawford has products and knowledge to help you design your new facility and/or modernise the existing one.

## About Crawford

Crawford is a leading ASSA ABLOY brand focusing on automated entrance solutions for efficient movement of vehicles and goods. With a complete portfolio of door and docking solutions, an extensive service offer and professional advice, we help customers ensure convenient, safe, secure and energy saving operations around-the-clock.

[www.crawfordsolutions.com](http://www.crawfordsolutions.com)



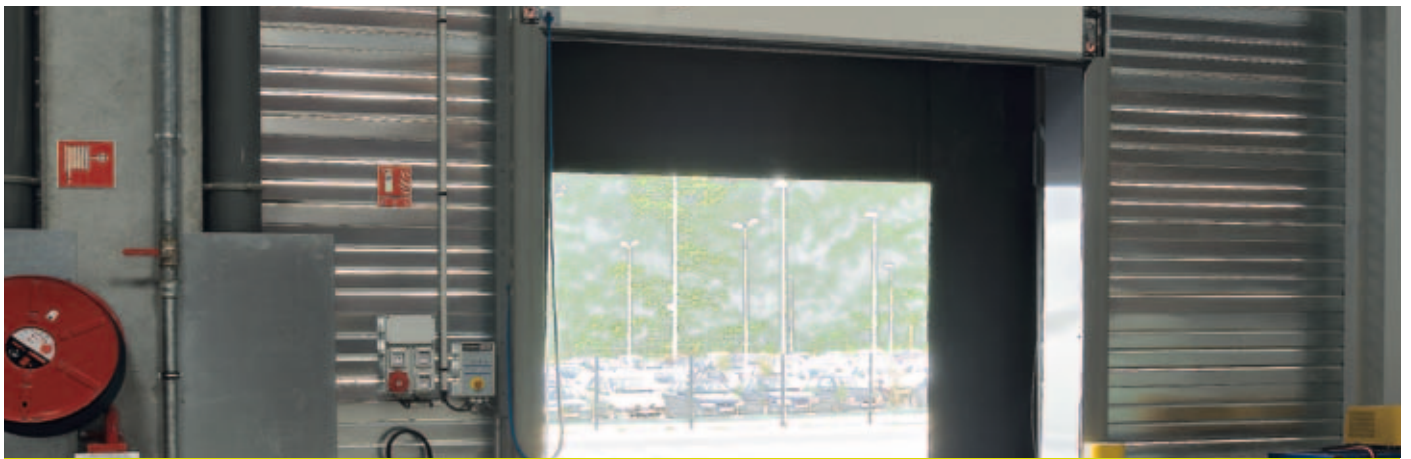

# Crawford Monitoring System – Energy Pack

## How can you reduce energy costs and contribute to a better environment?

You lose energy every time you open a door. That is especially true if a door is open when no truck is at the bay.

With a Crawford Monitoring System you can automatically ensure that no door will open unless there is a truck at the bay and even set it

to close when there is a gap in activity. All bays can be connected to the Monitoring System's server giving you the opportunity to supervise, monitor and report on a wide variety of aspects in your facility. You save money, you save energy and you can prove it.

## How does it work?

### 1. Each bay is connected via a serial bus cable to a computer

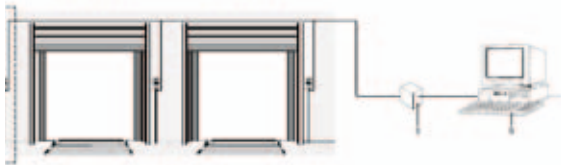

Crawford products with i-supervision or 950 docking control units can be connected directly to the server via a connection box.

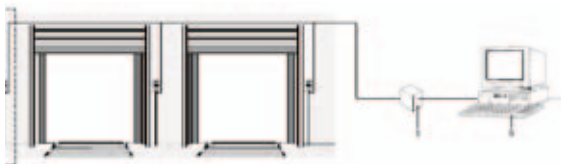

Products with other control boxes are connected via a D2G communication unit.

### 2. At the bay we install a sensor that will detect if the truck is docked

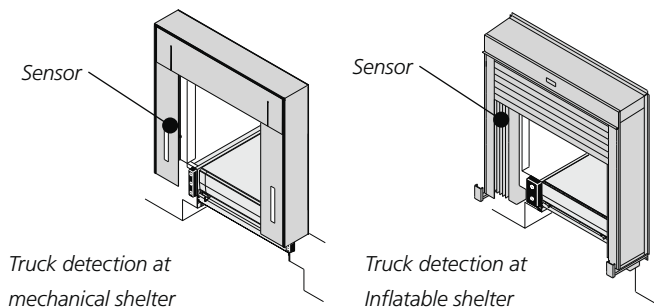

### 3. On the computer we install a web based server software that will monitor and control the activity at the bay



The server can be connected to Intranet or Internet. The software can also be installed, if required on a virtual server.

The access of the site is protected by a login with username and password giving the possibility to have users with different access rights.

The user has an overall view of the facility giving him complete control on what is happening at the docks. With the detailed view, the user has control on the activity at the bay. He knows what door is open or closed and how many trucks are at the bay. Doors are interlocked so that opening of the door is not possible if no truck is at the bay.

The system can also be upgraded with:

- An over ruling function to open the door even if no truck is at the bay
- The remote opening & closing of the door function
- The real time temperature at the bay information

 **Crawford**

**ASSA ABLOY**

# Crawford Monitoring System – Energy Pack

## 4. Activity Reports

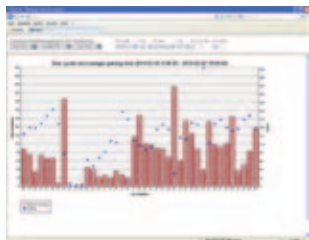

As we monitor all activities at the bay we can generate statistical report on the usage of the facility e.g: average time the door is opened, average time dock at the bay. The reports are available in Microsoft excel format.

## 5. Requirements

### Processor

Min Pentium D 3 GHz.

### RAM

Min 1 GB.

### Hard disk

10 GB of free space.

(the logging will require 5-30MB/Month).

### Printer

Microsoft Windows compatible.

### Interface

To connect the our BUS-system a free RS232 or USB interface should be provided.

### Software requirements

Windows 2000, Windows XP Professional, Windows 2000 Server, Windows 2003 Server R1 and R2, Windows 2008 Server, including Microsoft .NET 1.1.

## 6. Cable specification UNITRONIC® BUS PA

Transmission technology RS 485

Fine-wire strand of plain copper wires, cores twisted to pairs  
screening braid of copper wires

Temperature range: permanently mounted –30°C to +60°C

Conductor resistance: max. 44 Ohm/km

Characteristic Impedance: (loop) 100 +/- 20 Ohm

Pairs/cores and diameter in mm: 1 × 2 × 1,0 Ø

## Crawford can do much more



We can for instance make a survey of your installation and with the **Crawford Energy Losses Simulation** tool see what can to be done to minimize losses.

## For Energy Efficient New Buildings and Modernisation:

### Make your docking unit a temperature barrier

Even with doors closed, dock levellers, which are made of steel, are great heat exchangers.

To limit heat exchange, Crawford has developed Isodock and load-houses – docking concepts that seal the docking unit.

This can reduce thermal loss by as much as 80% compared to a traditional leveller solution.

### Shelter your business against energy losses

Well-maintained dock shelters and door sealing are good for your business.

A well-maintained shelter and sealing reduces energy loss by as much as 80% when the door is open and a truck is at the bay.

## About Crawford

*Crawford is a leading ASSA ABLOY brand focusing on automated entrance solutions for efficient movement of vehicles and goods. With a complete portfolio of door and docking solutions, an extensive service offer and professional advice, we help customers ensure convenient, safe, secure and energy saving operations around-the-clock.*

[www.crawfordsolutions.com](http://www.crawfordsolutions.com)

