



Copyright and Disclaimer Notice

Although the contents of this publication have been compiled with the greatest possible care, ASSA ABLOY Entrance Systems cannot accept liability for any damage that might arise from errors or omissions in this publication. We also reserve the right to make appropriate technical modifications/replacements without prior notice.

No rights can be derived from the contents of this document.

Color guides: Color differences may occur due to different printing and publication methods.

ASSA ABLOY, Crawford, Megadoor and hafa, as words and logos, are examples of trademarks owned by ASSA ABLOY Entrance Systems or companies within the ASSA ABLOY Group.

Copyright © ASSA ABLOY Entrance Systems 2006-2011

No part of this publication may be copied or published by means of scanning, printing, photocopying, microfilm or any other process whatsoever without prior permission in writing by ASSA ABLOY Entrance Systems.

All rights reserved



Technical facts

Features

Sizes - nominal length	700 mm	
Sizes - nominal width	1250, 2000, 2200 mm	
Vertical working range	Above dock:	0 - 100 mm
	Below dock:	0 - 100 mm
Lip material:	Steel	
Surface treatment:	Standard:	RAL 5010
	Option:	RAL 3002
		RAL 6005
		RAL 9005
		Hot dip galvanised

Performance

Load capacity:	4 tonnes (40kN)
	6 tonnes (60kN)
Surface treatment paint class 3:	160 µm Corrosive Category C3 M acc. DIN EN ISO 12944-2
Surface treatment galvanised:	Hot dip galvanised 80 µm Corrosive category C4 & C5-I M acc. DIN EN ISO 12944-2

Q3.0 - 2011

Contents

Copyright and Disclaimer Notice	2
<hr/>	
Technical facts.....	3
<hr/>	
Features	3
Performance	3
1. Description.....	5
<hr/>	
1.1 General.....	5
1.1.1 Application	5
1.1.2 Mode of operation.....	5
1.1.3 Overview.....	5
1.1.4 Standard.....	5
1.1.5 Options.....	5
1.2 Surface	6
1.2.1 Painting.....	6
1.2.2 Hot galvanising.....	6
2. Selection guide.....	7
<hr/>	
2.1 Load capacity according to EN 1398	7
2.1.1 Rated load.....	7
2.1.2 Axle load.....	7
2.1.3 Dynamic load.....	7
2.2 Select the load capacity	7
2.2.1 Example.....	7
3. Specifications.....	8
<hr/>	
3.1 Dimensions.....	8
4. Installation.....	9
<hr/>	
4.1 Ramp installation	9
4.1.1 Buffer options.....	9
4.2 Pit installation.....	10
4.2.1 Without tail lift recess.....	10
4.2.2 With tail lift recess	10
4.2.3 Buffer options.....	10
5. Service	11
<hr/>	
6. Index	12
<hr/>	

Q30 - 2011

1. Description

1.1 General

1.1.1 Application

The Crawford 613 minidock is a full Docking System especially developed for a limited working range, the ideal solution for a standardized fleet of vehicles. It is available as ramp model as well as pit model. The advantage of the ramp model is the quick installation which also can be done as add-on to existing ramps. The operation of the Crawford 613 minidock is mechanically and supported by a gas spring. You need only one person to lift the platform, swing out, and put the lip on the vehicle bed in one movement. The Crawford 613 minidock solution include the free floating position, the platform follow the vehicle's movements up and down during loading and unloading.

The dock leveller type Crawford 613 minidock meets all requirements of European directive EN 1398.

1.1.2 Mode of operation

The swing lip safely bridges the gap between the ramp and the lorry bed. By manually pulling the rod, the dock leveller is raised and the lip swings out. Then the leveller can be lowered gently onto the lorry bed. After loading or unloading, pulling the rod raises the leveller again, the lip swings down and the platform returns to its parking position, i.e. to ramp level.

1.1.3 Overview

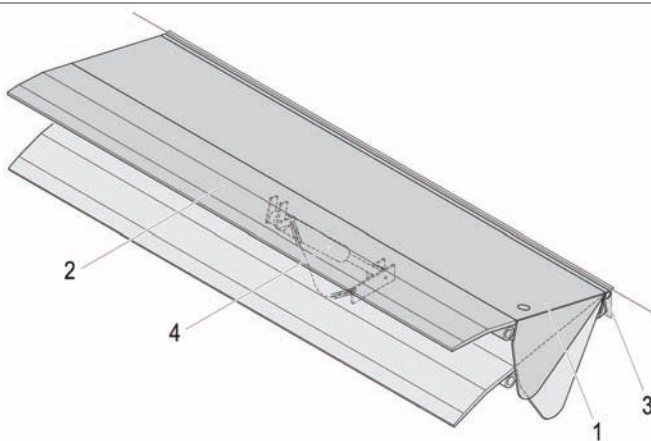

- 1 Leveller platform
- 2 Swing lip
- 3 Rear frame
- 4 Gas spring

1.1.4 Standard

Nominal length:	700 mm
Nominal width:	1250, 2000, 2200 mm
Load capacity:	4 tonnes (40 kN)
Surface:	Painting RAL 5010
Installation:	Ramp installation (steel support construction for buffers included)

1.1.5 Options

Load capacity:	6 tonnes (60 kN) (only available for nominal width 2000, 2200 mm)
Surface	Painting RAL 3002, 6005 or 9005 Hot galvanised
Installation:	Pit installation
Equipment:	Buffer RB Buffer RB with steel protection plate Buffer RB/2

1.2 Surface



1.2.1 Painting

1.2.1.1 Colours

The dock leveller standard finish is painted. The standard colours are:

	RAL 5010
---	----------

Colours available as option are:

	RAL 6005
	RAL 3002
	RAL 9005

1.2.1.2 Standard paint class

If the dock leveller is to be used in a rural area, the standard finish is:

- Paint class 2; 120 µm factory painted for corrosive category C2 M

1.2.1.3 Paint classes

If the dock leveller is to be used in an urban or industrial atmosphere, or in a coastal area, it may be appropriate to select an alternative paint class with increased resistance to corrosion C3 M.

- Paint class 3; 160 µm factory painted for corrosive category C3 M

1.2.2 Hot galvanising

To increase corrosion protection to C4 for saline coastal areas or C5-I for aggressive or humid atmospheres, the dock leveller can be delivered with hot dip galvanised (80 µm) steel parts.

2. Selection guide

2.1 Load capacity according to EN 1398

The EN 1398 describes 3 key definitions about loads.

2.1.1 Rated load

The rated load is the total weight of the goods, the forklift truck and the driver.



2.1.2 Axle load

Axle loads shall be taken acting over two rectangular contact areas at 1 m lateral distance. These areas shall only apply if the actual conditions do not call for more severe loading. The size of the footprint [mm²] is derived from the wheel load [N] divided by 2 [N/mm²]. The ratio of the rectangular print is $W:L = 3:2$.

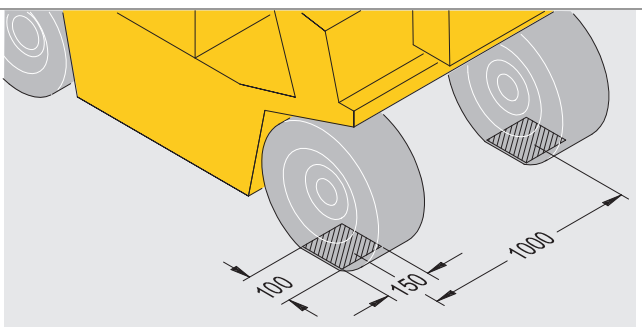

In the drawing measures for a leveller with a load capacity of 60kN.

2.1.3 Dynamic load

The dynamic load is the movement of the rated load and is the pressure on the leveller platform caused by the moving forklift truck.

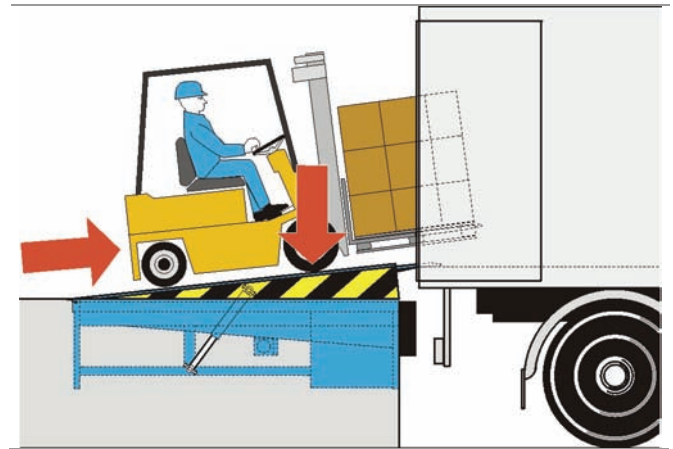

2.2 Select the load capacity

The load capacity of a dock leveller must always be higher than the rated load.

2.2.1 Example

Weight of forklift truck	3600 kg
Weight of goods	1500 kg
Weight of driver	100 kg
Total weight/rated load	5200 kg
Suitable load capacity of the leveller	6000 kg/60kN

3. Specifications

3.1 Dimensions

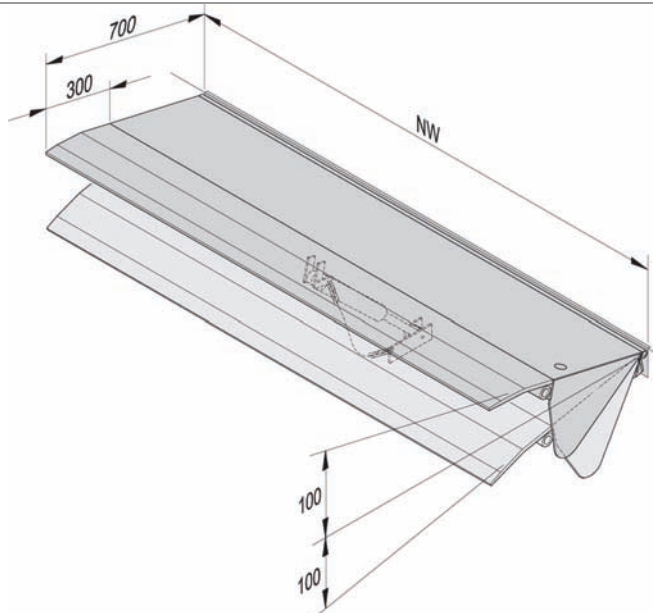

Nominal width	1250 mm (40 kN)
	2000 mm (40 kN, 60 kN)
	2200 mm (40 kN, 60 kN)
Nominal length	700 mm
Length of swing lip	300 mm
Vertical working range	100 mm

Q30 - 2011

4. Installation

This section illustrates the two installation modes for the Crawford 613 minidock.

- Ramp installation
- Pit installation
-

4.1 Ramp installation

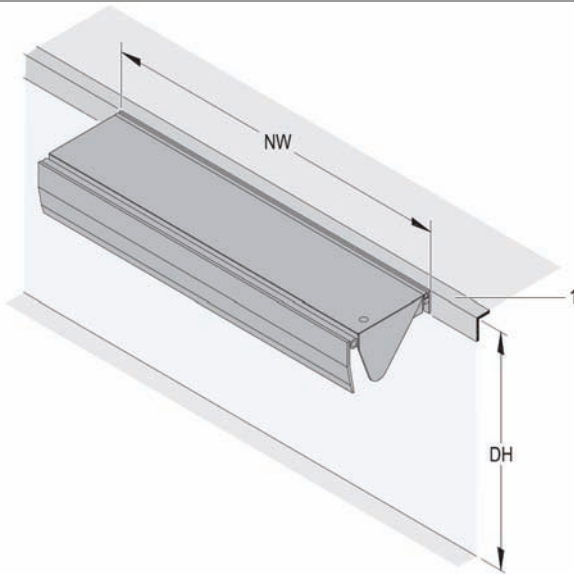

pit drawing 5143.0206	without tail lift recess
pit drawing 5143.0243	with tail lift recess

NW	Nominal width
DH	Dock height
1	Angle (by others)

4.1.1 Buffer options

4.1.1.1 RB/2: Buffer

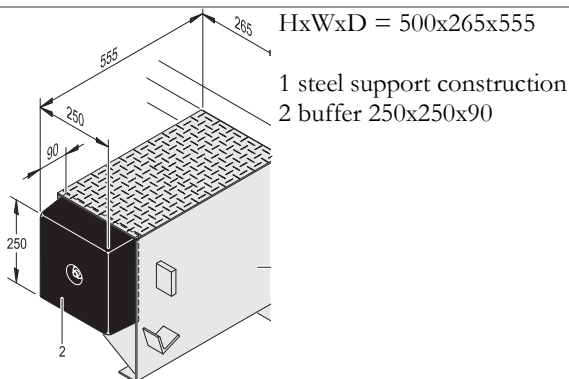

4.1.1.2 RB: Buffer

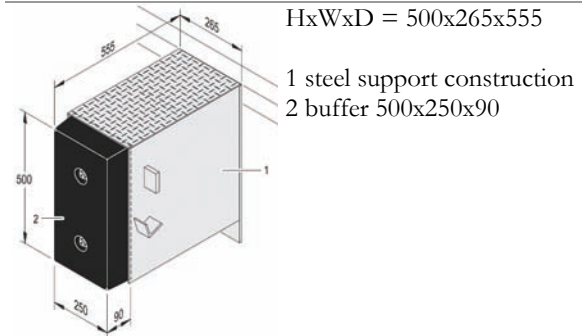

4.1.1.3 RB: Buffer with steel protection plate

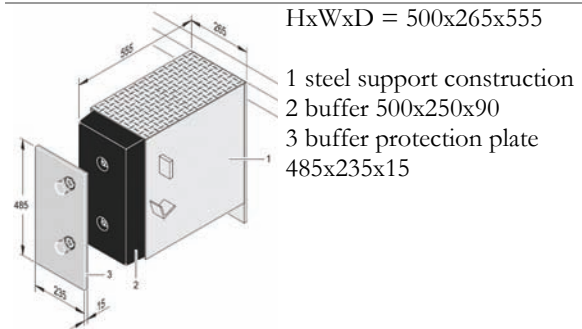

4.1.1.4 Bracket for steel support construction

Bracket for ramp installation with buffer construction RB 500y250x90 when the concrete cantilever plate is <math>< 370\text{mm}</math>.

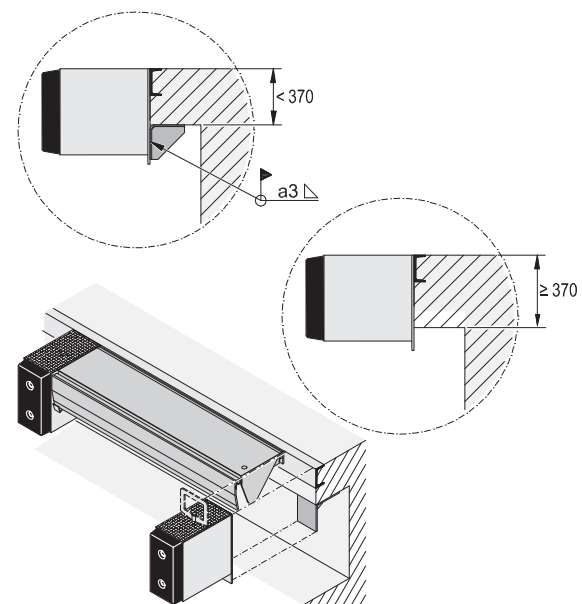

Q3.0 - 2011

4.2 Pit installation

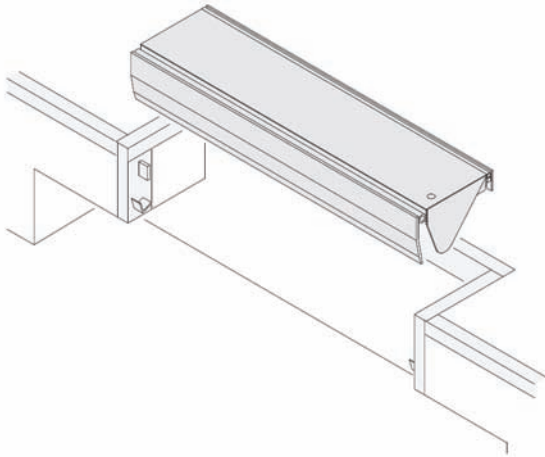

PL	pit length
PW	pit width
PD	pit depth
DH	dock height
1	angle (by others)
2	resting angles (by others)

4.2.1 Without tail lift recess

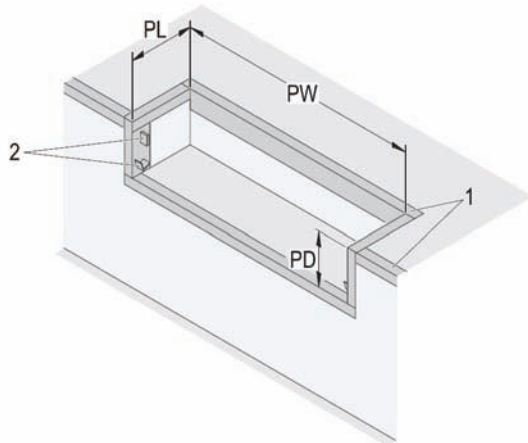

pit drawing 5143.0199

4.2.2 With tail lift recess

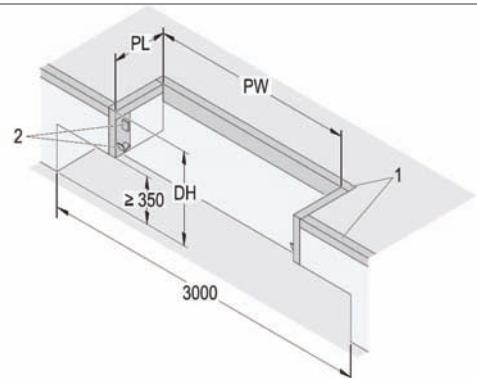

pit drawing 5143.0244

4.2.3 Buffer options

4.2.3.1 RB/2: Buffer

HxWxD = 250x250x90

1 buffer 250x250x90

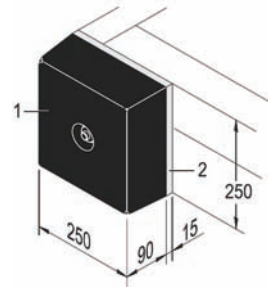

4.2.3.2 RB: Buffer

HxWxD = 500x250x90

1 buffer 500x250x90

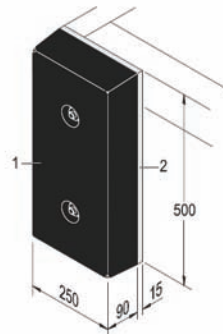

4.2.3.3 RB: Buffer with steel protection plate

HxWxD = 500x250x105

1 buffer 500x250x90
2 buffer protection plate
485x235x15

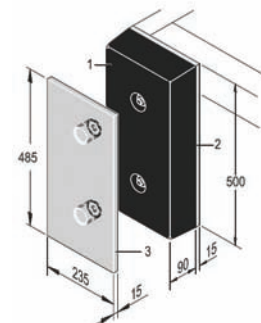

5. Service



These keys open doors to better business

Regardless of their function, age or manufacturer, your industrial doors and dock loading systems have an important role in the flow of your business. That's why it makes sense to plan their maintenance long before the need for service occurs.

A Key Customer Service agreement from Crawford is your best assurance of safe and trouble-free door and dock operation. By becoming a key customer, you not only reduce the risk of breakdowns, but also guarantee compliance with local regulations and the new harmonised EU standards. You also ensure that your doors and dock loading systems retain their classifications for wind load, air permeability, water penetration and more.

Four types of Key Customer Service agreement – Green, Yellow, Blue and Red – allow us to tailor our service to your specific needs. Based on the role of your doors and dock loading systems, and the intensity with which you use them, you receive service that provides the perfect balance of economy, safety and security.

Best of all, the maintenance is performed by Crawford's renowned team of service technicians. As a qualified specialist in industrial doors and dock loading systems, we have the knowledge and skills to service any door or dock, regardless of its type, age or manufacturer. With Crawford as a single source for all your door and docking equipment brands, you can easily reduce costs while increasing equipment availability.

6. Index

A

Application.....	5
Axle load	7

B

Bracket for steel support construction.....	9
Buffer options	9, 10

C

Colours.....	6
Copyright and Disclaimer Notice	2

D

Description	5
Dimensions	8
Dynamic load	7

E

Example	7
---------------	---

F

Features	3
----------------	---

G

General	5
---------------	---

H

Hot galvanising.....	6
----------------------	---

I

Installation.....	9
-------------------	---

L

Load capacity according to EN 1398	7
---	---

M

Mode of operation	5
-------------------------	---

O

Options.....	5
Overview	5

P

Paint classes	6
Painting	6
Performance.....	3
Pit installation	10

R

Ramp installation	9
Rated load	7
RB	
Buffer	9, 10
Buffer with steel protection plate.....	9, 10
RB/2	
Buffer	9, 10

S

Select the load capacity.....	7
Selection guide	7
Service	11
Specifications	8
Standard	5
Standard paint class	6
Surface	6

T

Technical facts.....	3
----------------------	---

W

With tail lift recess.....	10
Without tail lift recess.....	10





Crawford is a leading ASSA ABLOY brand focusing on automated entrance solutions for efficient movement of vehicles and goods. With a complete portfolio of door and docking solutions, an extensive service offer and professional advice, we help customers ensure convenient, safe, secure and energy saving operations around-the-clock.

Crawford is represented in more than 30 countries and is part of ASSA ABLOY Entrance Systems, which also includes the globally recognized Megadoor and Besam brands.

www.crawfordsolutions.com



Crawford

ASSA ABLOY