



Q2.0 - 2011

Copyright and Disclaimer Notice

Although the contents of this publication have been compiled with the greatest possible care, ASSA ABLOY Entrance Systems cannot accept liability for any damage that might arise from errors or omissions in this publication. We also reserve the right to make appropriate technical modifications/replacements without prior notice.

No rights can be derived from the contents of this document.

Color guides: Color differences may occur due to different printing and publication methods.

ASSA ABLOY, Crawford, Megadoor and hafa, as words and logos, are examples of trademarks owned by ASSA ABLOY Entrance Systems or companies within the ASSA ABLOY Group.

Copyright © ASSA ABLOY Entrance Systems 2006-2011

No part of this publication may be copied or published by means of scanning, printing, photocopying, microfilm or any other process whatsoever without prior permission in writing by ASSA ABLOY Entrance Systems.

All rights reserved

Technical facts

Features

Sizes - nominal length*	2000, 2450, 3000 mm
Sizes - nominal width*	3300, 3500, 3600, 3750 mm
Insulated cladding:	
Thickness of insulation:	Roof and wall panels with 40 mm insulation
Surface treatment:	Hot dip galvanised Inside colour-coated Outside colour coated 25 µm
Uninsulated cladding:	
Thickness of material:	0,6 mm profiled steel sheet
Surface treatment:	Hot dip galvanised Inside protective coating 10 µm Outside colour-coating 25 µm
Surface steel frame:	Hot dip galvanised

* Other sizes are available on request

Performance

Basic Windload	0,84 kN/m ²	Eurocode 3
Basic snow load	2,00 kN/m ²	Eurocode 3
Accumulated snow load	3,50 kN/m ²	Eurocode 3

Observe the local building regulations

Contents

Copyright and Disclaimer Notice	2
<hr/>	
Technical facts	3
<hr/>	
Features	3
Performance	3
1. Description	5
<hr/>	
1.1 General	5
1.1.1 Application	5
1.1.2 Advantages	5
1.1.3 Overview	5
1.1.4 Standard	5
1.1.5 Options	5
1.1.6 Model HM - House mechanical	6
1.1.7 Model HI - House inflatable	6
1.2 Cladding types	6
1.2.1 I - Insulated	6
1.2.2 U - Uninsulated	6
1.2.3 X - Steel frame	7
1.2.4 Angular adjustment	7
1.2.5 Drain pipe and gutter	7
1.2.6 Anti-drip-coating (only for cladding type U - uninsulated)	7
1.2.7 Wall profile and water nose	8
1.2.8 Protrusion on façade	8
1.2.9 Wall protection plywood veneer	8
2. Specifications	9
<hr/>	
2.1 Dimensions HM	9
2.2 Shelter selection guide HM	9
2.3 Dimensions HI	10
3. Building and space requirements	11
<hr/>	
3.1 Wall fixings	11
3.1.1 Fixing heights	11
3.1.2 Maximum wall fixing force (kN)	12
3.1.3 Wall fixing details (X)	12
3.1.4 Wall fixings	12
4. Service	13
<hr/>	
5. Index	14
<hr/>	

Q2.0 - 2011

1. Description

1.1 General

1.1.1 Application

The Crawford 680 load house is a loading system that represents a complete and stand-alone unit that is installed in front of the building. It comprises all components of a docking system: an Autodock leveller, a dock shelter and an overhead sectional door. These components are presented in their individual product datasheets. This product datasheet describes the steel cladding; the load house in which all components are integrated.

Since it is installed outside the building directly in front of the door opening it has great advantages over a conventional internal ramp for both new buildings as well as for existing buildings that are to be upgraded without any major modifications to the construction of the building. As a standard the entire steel frame construction of the Crawford 680 load house is hot dip galvanised. Recommended options are a roof drainage system and flashing, adapted to your building.

1.1.2 Advantages

- Thermal separation of warehouse and docking system guarantees considerable energy saving, important for temperature controlled and freezer warehouses.
- Easy and fast installation of pre-assembled components on existing foundations which can be fastened on the outside wall of the building, without disrupting the daily use of the building.
- The cladding consists either of non-insulated profile sheet material or of 40 mm insulation panels; it can also be cladded with the material of the warehouse facade.
- The Crawford 680 load house design allows the use of an Autodock swinglip or telescopic lip leveller and the installation of a mechanical or inflatable dock shelter, whatever best suits the loading frequency.
- Because of individual components it can be installed as a single house or a multiple system.
- The single house can be installed at a 45° or 135° angle if the room in front of the loading system is limited.
- The storage room in the warehouse is extended since the complete docking system is placed outside the building.
- Even shorter tax depreciation periods are possible. Please ask your tax lawyer.

1.1.3 Overview

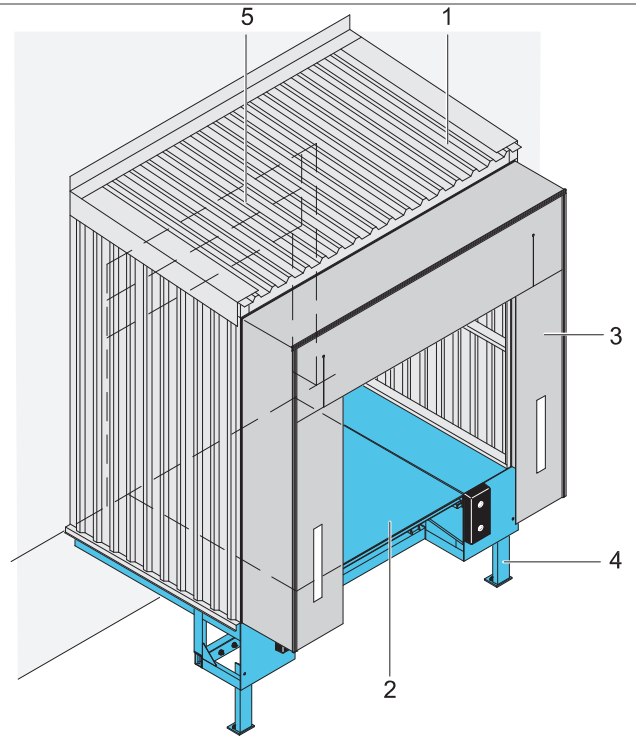

- | | |
|---|----------------------------|
| 1 | Steel cladding |
| 2 | Autodock leveller |
| 3 | Dock shelter |
| 4 | Autodock support structure |
| 5 | Overhead sectional door |

1.1.4 Standard

Nominal length:	2000, 2450, 3000 mm
Nominal width:	3300, 3500, 3600, 3750 mm
Angular adjustment:	90°

1.1.5 Options

Models:	HM - house mechanical HI - house inflatable
Cladding types:	I - insulated U - uninsulated X - steel frame
Angular adjustments:	45° or 135°
Roof:	Drain pipe and gutter Anti-drip-coating
Wall:	Wall connection profile Wall protection plywood veneer

Q2.0 - 2011

1.1.6 Model HM - House mechanical

The model HM is designed for an Autodock leveller with a mechanical dock shelter type SME or SMP. This load house model is the most economical solution for external dock installations.

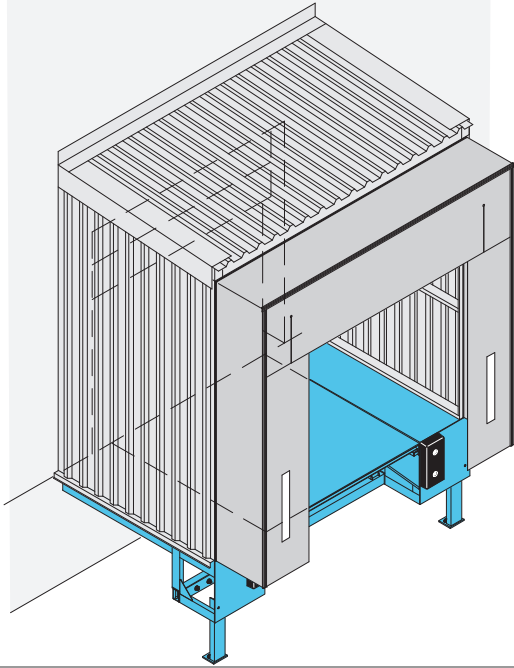

1.1.7 Model HI - House inflatable

The model HI is designed for an Autodock leveller with an inflatable dock shelter type SIR or SIB. This load house model provides a high degree of sealing.

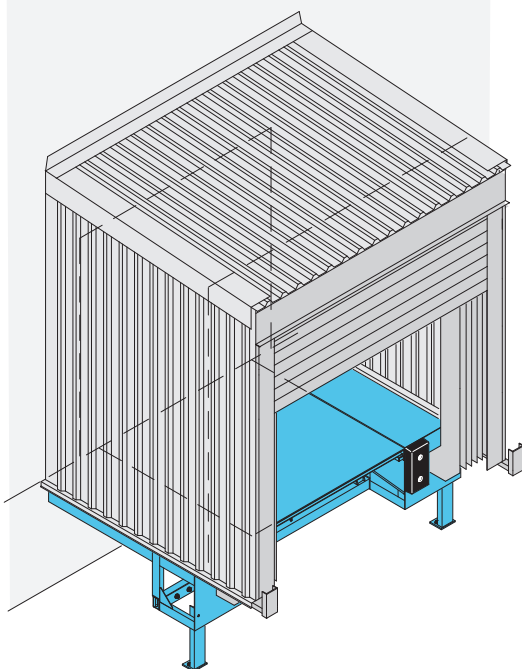

1.2 Cladding types

1.2.1 I - Insulated

For optimal insulation the I-insulated type is provided with 40 mm insulated cladding.

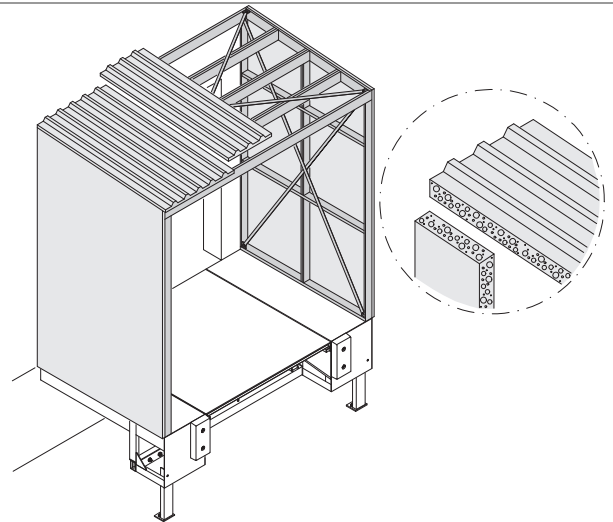

1.2.2 U - Uninsulated

The U-uninsulated type is provided with non-insulated profile sheet material cladding.

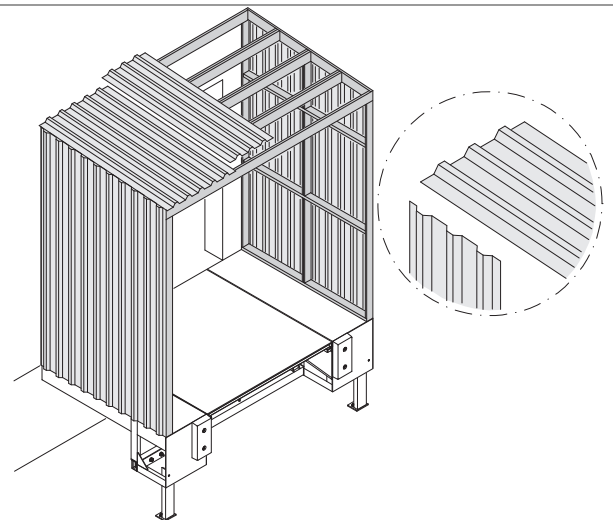

Q2.0 - 2011

1.2.3 X - Steel frame

For applications where the existing building facade cladding is used, the X-steel frame type is provided with only a steel frame.

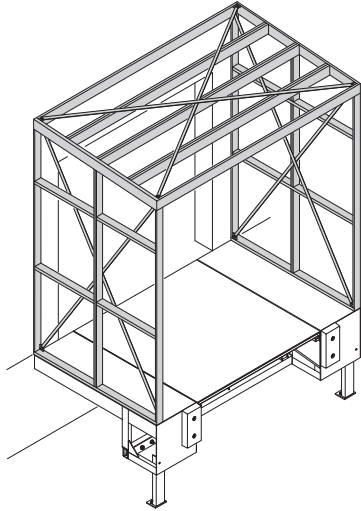

1.2.4 Angular adjustment

For applications where the yard space is limited, the load house can be installed with angular adjustments.

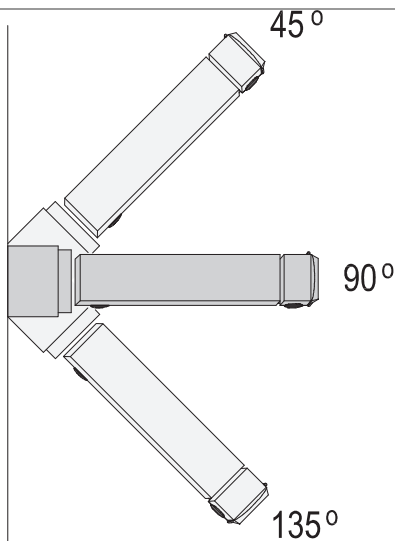

1.2.5 Drain pipe and gutter

To have controlled water drainage, the load house can be equipped with drain pipe and gutter.

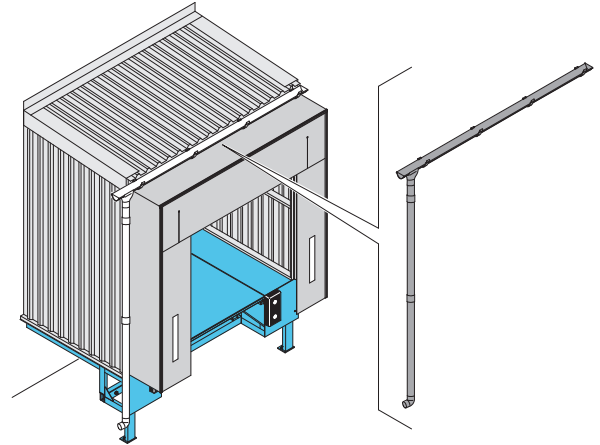

1.2.6 Anti-drip-coating (only for cladding type U - uninsulated)

To avoid condense water leading to moisture in the loading area, the inside surface of the roof sheet material can be delivered with a layer of felt as anti-drip-coating.

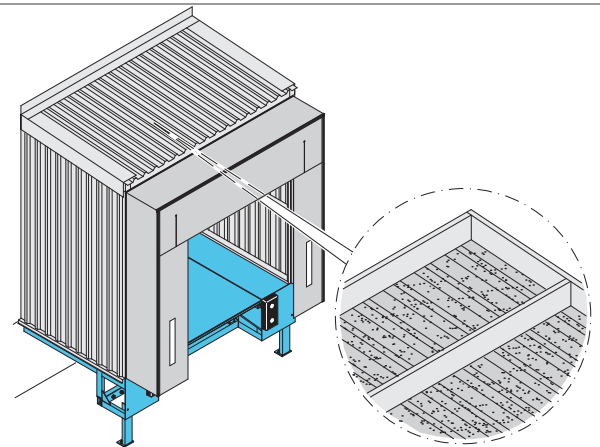

Q2.0 - 2011

1.2.7 Wall profile and water nose

To connect the load house structure to the building, horizontal angle profiles including sealing material can be included in the installation. Water is led off the loadhouse by a water nose on the side.

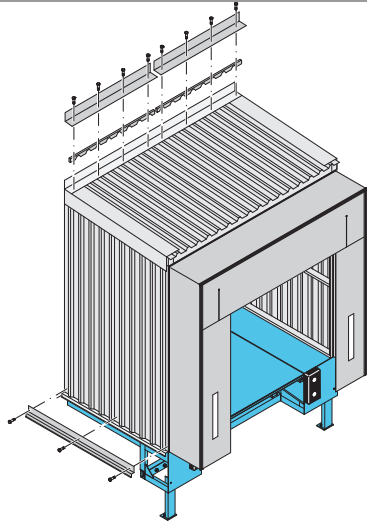

1.2.9 Wall protection plywood veneer

To protect the walls inside the load house against possible damages from the handling equipment, the lower part can be equipped with a cover of a plywood veneer (1200 mm high). This is also the recommended solution for applications where the inside walls need to be closed and have a straight surface.

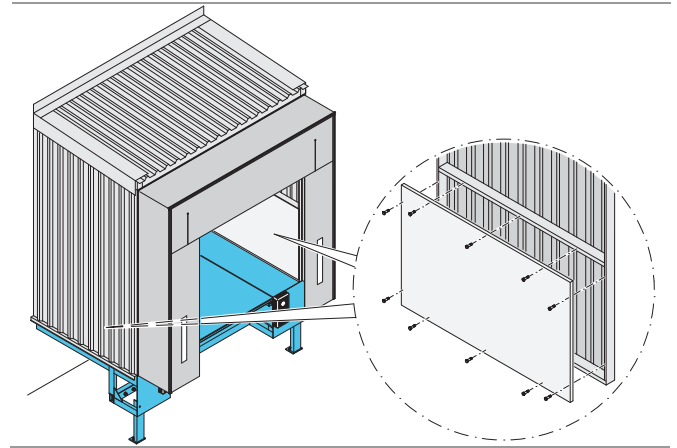

1.2.8 Protrusion on façade

In order to meet all kind of façades a protrusion on the façade of +100mm to -100mm is available.

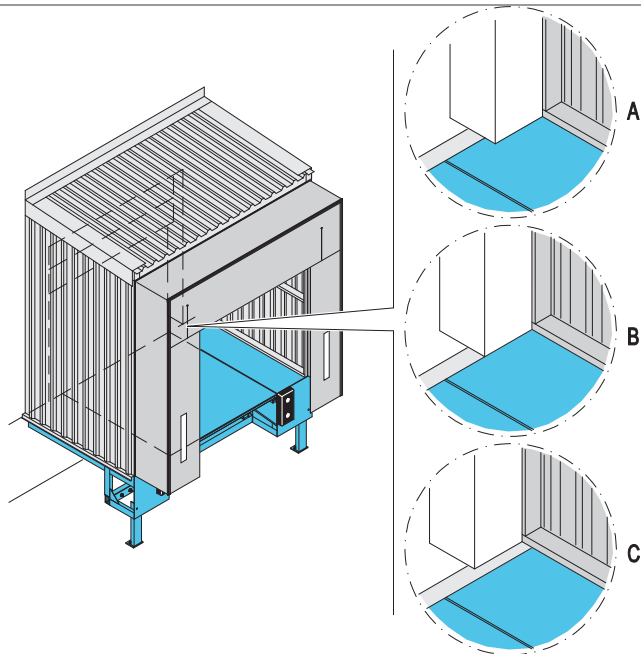

- (A) positive protrusion
- (B) no protrusion
- (C) negative protrusion

Q2.0 - 2011

2. Specifications

2.1 Dimensions HM

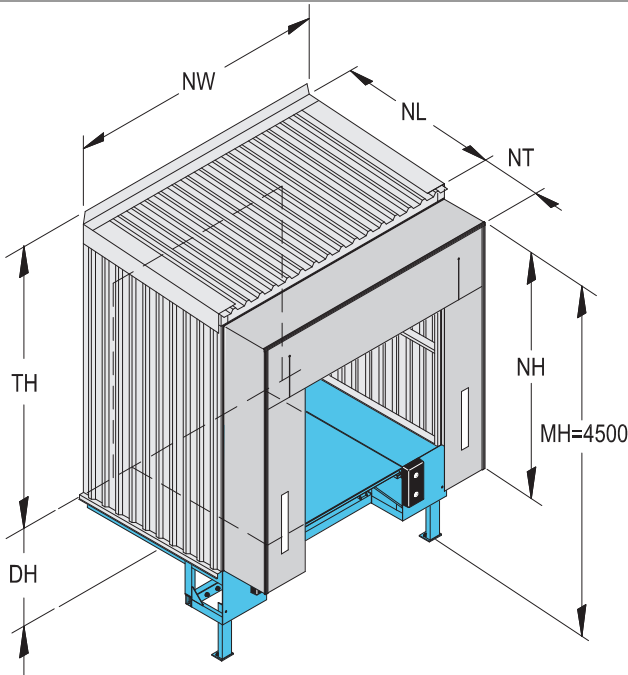

NW	Nominal width [3300, 3500, 3600 mm]
NL	Nominal length
TH	Total height
DH	Dock height
NH	Nominal height dock shelter
NT	Nominal width dock shelter
MH	Assembly height dock shelter Recommendation: MH=4500 for lorry-heights up to 4000 mm

		Total Height -> TH*		
		NL 2000	NL 2450	NL 3000
DH	950	3880	3910	3950
	1000	3830	3860	3900
	1050	3780	3810	3850
	1100	3730	3760	3800
	1150	3680	3710	3750
	1200	3630	3660	3700
	1250	3580	3610	3650
	1300	3530	3560	3600
	1350	3480	3510	3550
	1400	3430	3460	3500
	1450	3380	3410	3450
	1500	3330	3360	3400

* Measurement only valid for insulated wall setup.
For uninsulated wall setup TH is 60mm less. When Loadhouse is supplied with rain pipe and gutter add 100mm.

2.2 Shelter selection guide HM

Depending on the installation type (single or multi) and the width of the load house, the right selection of the type of mechanical shelter & nominal width is indicated in this table.

HM type	HM width	SMP NW 3200	SME/SMP NW 3250	SMP NW 3400	SME/SMP NW 3450	SMP NW 3500
Multi	3300	■				
Single	3300		■			
Multi	3500			■		
Single	3500				■	
Multi	3600					■
Single	3600					■

2.3 Dimensions HI

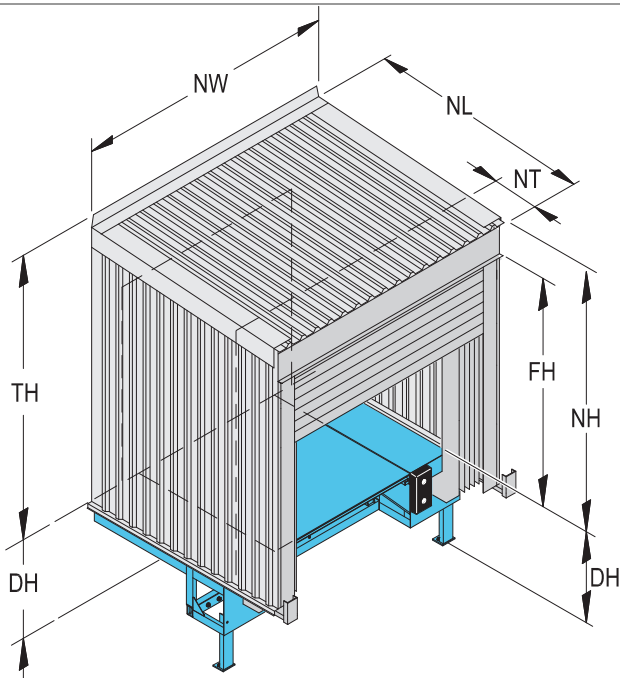

NW	Nominal width [3600, 3750** mm]
NL	Nominal length
TH	Total height
DH	Dock height
NH	Nominal height dock shelter
NT	Nominal width dock shelter
FH	Free height above finish floor level

		Total Height -> TH*		
NH	FH	NL 2000	NL 2450	NL 3000
3555	3100	3880	3920	3960
3755	3300	4080	4120	4160
4055	3600	4380	4420	4460
4355	3900	4680	4720	4760
4555	4100	4880	4920	4960

* Measurement only valid for insulated wall setup.

Q2.0 - 2011

3. Building and space requirements

3.1 Wall fixings

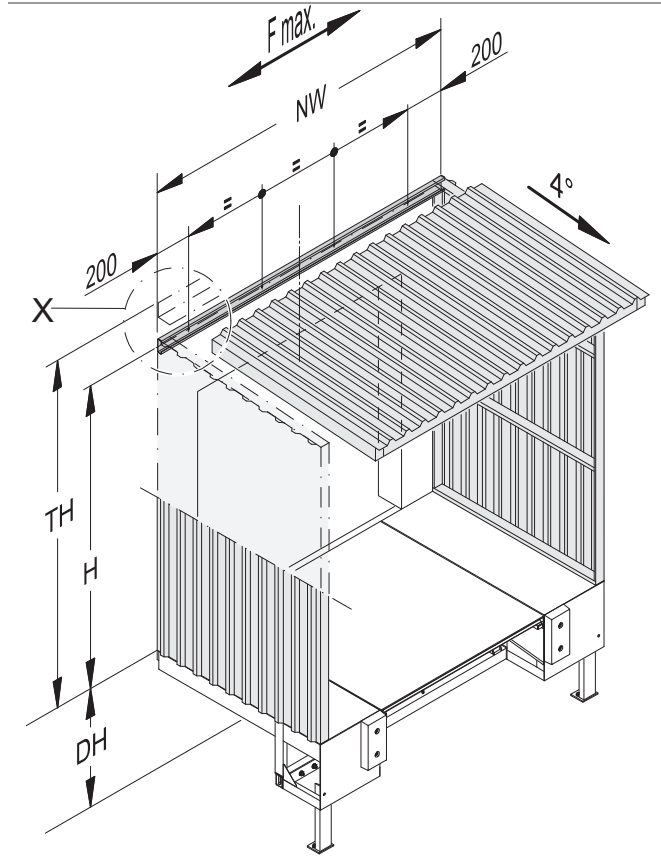

* F max. = Maximum wall fixing force (kN)

Fixing heights

TH insulated	TH uninsulated	Fixing height
3330	3270	3090
3360	3300	3120
3380	3320	3140
3400	3340	3160
3410	3350	3170
3430	3370	3190
3450	3390	3210
3460	3400	3220
3480	3420	3240
3500	3440	3260
3510	3450	3270
3530	3470	3290
3550	3490	3310
3560	3500	3320
3580	3520	3340
3600	3540	3360
3610	3550	3370
3630	3570	3390
3650	3590	3410
3660	3600	3420
3680	3620	3440
3700	3640	3460
3710	3650	3470
3730	3670	3490
3750	3690	3510
3760	3700	3520
3780	3720	3540
3800	3740	3560
3810	3750	3570
3830	3770	3590
3850	3790	3610
3860	3800	3620
3880	3820	3640
3900	3840	3660
3910	3850	3670
3920	3860	3680
3950	3890	3710
3960	3900	3720
4080	4020	3840
4120	4060	3880
4160	4100	3920
4380	4320	4140
4420	4360	4180
4460	4400	4220
4680	4620	4440
4720	4660	4480
4760	4700	4520
4880	4820	4640
4920	4860	4680
4960	4900	4720

Q2.0 - 2011

3.1.1 Maximum wall fixing force (kN)

NL	F max.
2000 mm	6,3 kN
2450 mm	6,3 kN
3000 mm	7,5 kN

3.1.2 Wall fixing details (X)

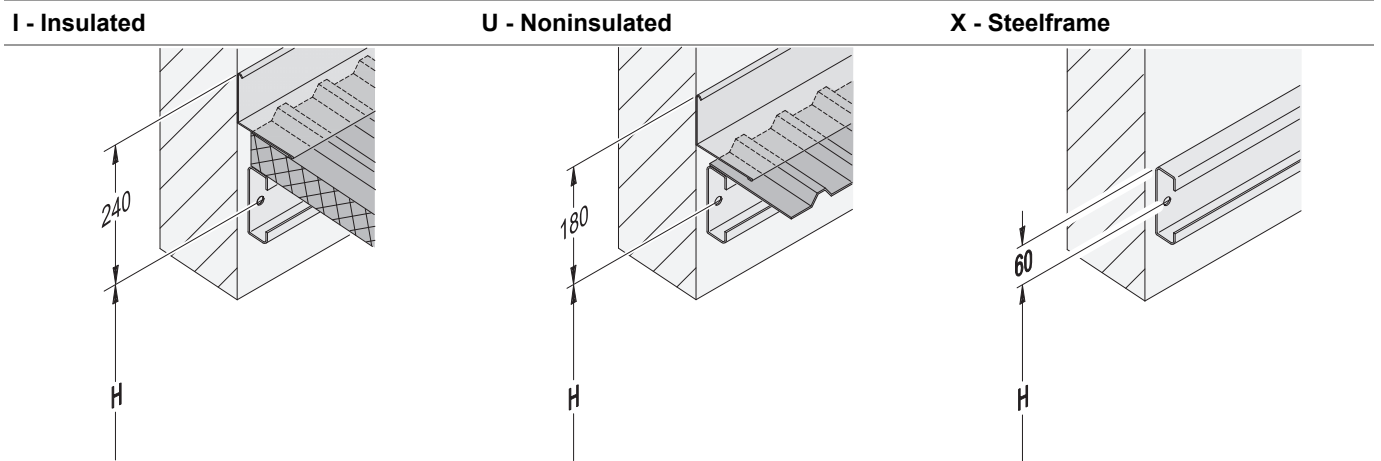

H fixing height (min. 100 mm above door height)

3.1.3 Wall fixings

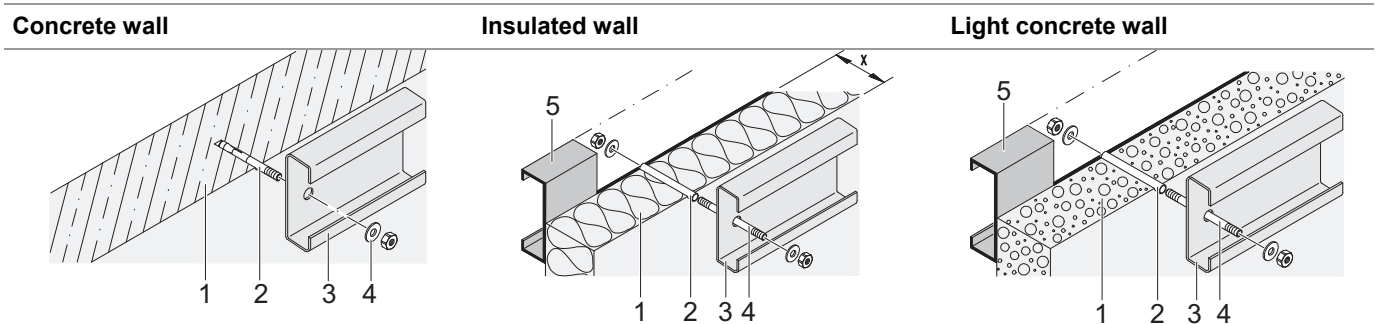

Concrete wall	Insulated wall	Light concrete wall
1 Concrete wall	1 Insulated wall	1 Light concrete wall
2 Dowel	2 Spacer tube	2 Spacer tube
3 Roof profile	3 Roof profile	3 Roof profile
4 Washer	4 Threaded bolt with nut and washer	4 Threaded bolt with nut and washer
	5 Mounting frame *	5 Mounting frame* (eg. c-profile 120x40x15x3 mm)
	X Wall thickness (x=100 or 120 mm)	

Q2.0 - 2011

4. Service



These keys open doors to better business

Regardless of their function, age or manufacturer, your industrial doors and dock loading systems have an important role in the flow of your business. That's why it makes sense to plan their maintenance long before the need for service occurs.

A Key Customer Service agreement from Crawford is your best assurance of safe and trouble-free door and dock operation. By becoming a key customer, you not only reduce the risk of breakdowns, but also guarantee compliance with local regulations and the new harmonised EU standards. You also ensure that your doors and dock loading systems retain their classifications for wind load, air permeability, water penetration and more.

Four types of Key Customer Service agreement – Green, Yellow, Blue and Red – allow us to tailor our service to your specific needs. Based on the role of your doors and dock loading systems, and the intensity with which you use them, you receive service that provides the perfect balance of economy, safety and security.

Best of all, the maintenance is performed by Crawford's renowned team of service technicians. As a qualified specialist in industrial doors and dock loading systems, we have the knowledge and skills to service any door or dock, regardless of its type, age or manufacturer. With Crawford as a single source for all your door and docking equipment brands, you can easily reduce costs while increasing equipment availability.

5. Index

A

Advantages	5
Angular adjustment	7
Anti-drip-coating (only for cladding type U - uninsulated)..	7
Application.....	5

B

Building and space requirements	11
---------------------------------	----

C

Cladding types	6
Copyright and Disclaimer Notice	2

D

Description	5
Dimensions HI.....	10
Dimensions HM.....	9
Drain pipe and gutter.....	7

F

Features	3
Fixing heights	11

G

General	5
---------------	---

I

I - Insulated	6
---------------------	---

M

Maximum wall fixing force (kN)	12
Model HI - House inflatable	6
Model HM - House mechanical	6

O

Options.....	5
Overview	5

P

Performance.....	3
Protrusion on façade	8

S

Service	13
Shelter selection guide HM	9
Specifications	9
Standard.....	5

T

Technical facts	3
-----------------------	---

U

U - Uninsulated.....	6
----------------------	---

W

Wall fixing details (X)	12
Wall fixings	11, 12
Wall profile and water nose	8
Wall protection plywood veneer	8

X

X - Steel frame.....	7
----------------------	---



Crawford is a leading ASSA ABLOY brand focusing on automated entrance solutions for efficient movement of vehicles and goods. With a complete portfolio of door and docking solutions, an extensive service offer and professional advice, we help customers ensure convenient, safe, secure and energy saving operations around-the-clock.

Crawford is represented in more than 30 countries and is part of ASSA ABLOY Entrance Systems, which also includes the globally recognized Megadoor and Besam brands.

www.crawfordsolutions.com

