

Crawford
521 Folding door

Product datasheet



Q1.0 - 2012

Copyright and Disclaimer Notice

Although the contents of this publication have been compiled with the greatest possible care, ASSA ABLOY Entrance Systems cannot accept liability for any damage that might arise from errors or omissions in this publication. We also reserve the right to make appropriate technical modifications/replacements without prior notice. No rights can be derived from the contents of this document.

Color guides: Color differences may occur due to different printing and publication methods.

ASSA ABLOY, Crawford, Megadoor and hafa, as words and logos, are examples of trademarks owned by ASSA ABLOY Entrance Systems or companies within the ASSA ABLOY Group.

Copyright © ASSA ABLOY Entrance Systems 2006-2012.

No part of this publication may be copied or published by means of scanning, printing, photocopying, microfilm or any other process whatsoever without prior permission in writing by ASSA ABLOY Entrance Systems.

All rights reserved



Technical facts

Features

Max size: (W x H)*	7590 x 6000 mm	
Leaf thickness:	50 mm	
Material:	CFC-free polyurethane with sheet metal inner and outer skins	
Colour outside / inside:	Standard 5 pre-coated colours	
Windows:	TG1, TG2, TG5	
Passdoor:	Optional: built in door leaf, built in fixed section, leaf as passdoor	
Electrical operation:	Manual operation	Electrical operation: Automated operation, Access control, Safety functions

* Other sizes are available on request

Performance

Life time expectations:	Door: 300.000 door cycles/20 years (with the recommended yearly service check)	
Wind load, EN12424	Manual operated door: Class 3**	Electrical operated door: Class 5**
Thermal transmittance, EN12428	1,7 W/m ² .k ***	
Water penetration, EN12425	Class 3	
Air permeability, EN12426	Class 2	

** Up to DLW 3500 mm x DLH 3000

*** Door configuration 4000 mm x 4000 mm, 2 + 2

Contents

Copyright and Disclaimer Notice.....	2
--------------------------------------	---

Technical facts.....	3
----------------------	---

Features	3
Performance	3

1. Description.....	6
---------------------	---

1.1 General.....	6
1.1.1 Standard.....	6
1.1.2 Options.....	6
1.2 Door leaves	7
1.2.1 Construction	7
1.2.2 Material.....	7
1.2.3 Colours	7
1.2.4 Seals.....	8
1.2.5 Windows	9
1.2.6 Passdoor	10
1.2.7 Fixed sections.....	10
1.3 Manually operated door.....	11
1.3.1 Handle.....	11
1.3.2 Locks.....	11
1.4 Electrically operated door.....	12
1.4.1 Electrical operation	12
1.4.2 CDM9 FD Operating system.....	12
1.5 Access and automation	13
1.5.1 Basic control functions.....	13
1.5.2 External control functions	13
1.5.3 Automatic control functions.....	13
1.5.4 Safety functions.....	14
1.5.5 Additional functions	14
1.6 Monitoring systems	15
1.6.1 Saving energy	15
1.6.2 Security enhancement.....	15
1.6.3 Dock management.....	15
1.6.4 Facility management.....	15

2. Specifications.....	16
------------------------	----

2.1 Dimensions.....	16
2.1.1 Daylight width and daylight height.....	16
2.1.2 Section sizes	16
2.2 Configurations.....	16
2.3 Passdoor.....	17
2.3.1 Passdoor in doorleaf	17
2.3.2 Doorleaf as a passdoor.....	17
2.4 Door operation.....	17
2.4.1 Selection guidelines for operation type	17
2.4.2 950 door control system functions.....	18
2.4.3 950 door control system - Selection guidelines for automation	18



3.	CEN Performance	19
3.1	Lifetime expectation	19
3.2	Resistance to windload	19
3.3	Resistance to water penetration	19
3.4	Air permeability	19
3.5	Thermal transmittance	19
3.6	Operating forces and safe openings	19
4.	Building and space requirements	20
4.1	Building preparations	20
4.1.1	Installation preparations	20
4.1.2	Electrical preparations	20
4.2	Space requirements	21
4.2.1	Dimension terminology	21
4.2.2	Space requirements manual doors	21
4.2.3	Space requirements electrically operated doors	21
4.2.4	Depth	21
5.	Service	22
6.	Index	23

1. Description

1.1 General

The Crawford 521 folding door is one of the most stable folding doors on the market.

It is a well insulated folding door especially developed for demanding industrial environments. High flexibility makes it possible to install this door in almost every type of building.

The door slides (folds) to the left, right, or in both directions if it is in two parts, leaving the door opening completely free.

The door is made of aluminum tubular profiles, profiled steel sheets and injection moulded foam to make a stable sandwich construction.

The door can be installed on either the inside or the outside of the exterior wall. A wide range of options is available to suit the appearance of the existing building.

The Crawford 521 folding door has been designed to meet all operational and safety requirements in the European Directives and the standards issued by the European Standardization Committee, CEN.

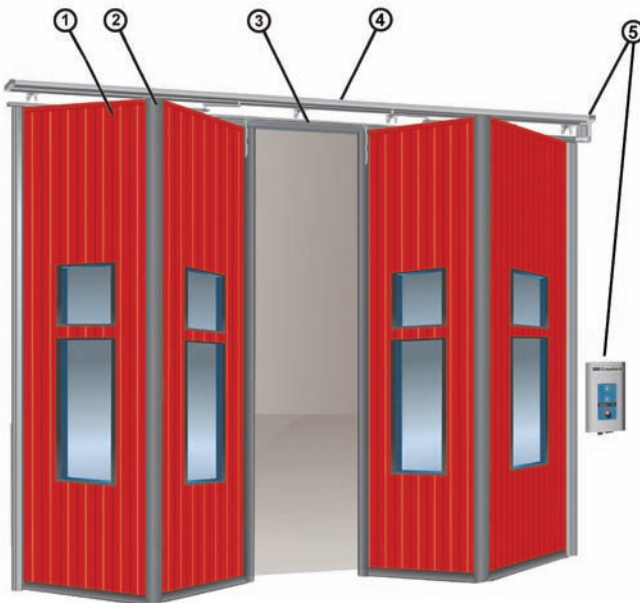

The Crawford 521 folding door has 5 primary parts:

1. Door leaf
2. Seals
3. Track
4. Transmission system (electrically operated door)
5. Operating system (electrically operated door)

1.1.1 Standard

Although every Crawford door is custom built, the Crawford 521 folding door is supplied with the following specifications as standard:

Door leaf:	Aluminium frames covered with steel sheets and filled with polyurethane insulation.
Operation:	Manual: Auto lock in open position Electrical: 950 door control system
Locks:	Cremona lock inside (manual operation)
Colours:	5 Pre-coated colours
Number of door leaves:	Max. 3 door leaves per side.
Safety:	Side cover

1.1.2 Options

Crawford provides a wide range of options and accessories to customise the Crawford 521 folding door to any customer's needs.

Passdoor:	Built in door leaf Built in fixed section Entire leaf as passdoor
Windows:	TG1/TG2/TG5: Double sided insulated hardened glass
Locks:	Assa lock box Euro lock box Kaba lock box Abloy lock box
Painting:	Factory painting any colour on request
Operation:	Delivered with or prepared for: Key locks system Automated operation, safety functions.



1.2 Door leaves

1.2.1 Construction

The Crawford 521 folding door comprises vertical door leaves, connected together with hinges. Rollers are installed on the top left and right of each door leaf. The rollers run in the top track to enable opening and closing of the door.

1.2.2 Material

The sections are made of aluminium profiles, clad with sheet metal panels, insulated with polyurethane foam.

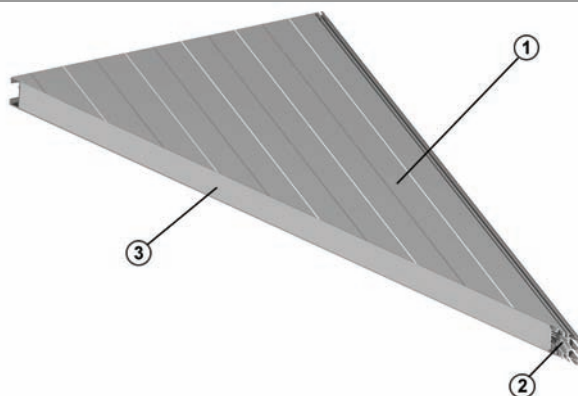



1. Rilled steel sheet
2. Aluminium frame
3. Polyurethane insulation

1.2.3 Colours

The Crawford 521 folding door is available in any colour on request.

1.2.3.1 Standard colours

As a standard, the Crawford 521 folding door door is available in 5 precoated colours.

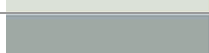
	RAL 3002
	RAL 5010
	RAL 7016
	RAL 9002
	RAL 9006

1.2.3.2 Optional colours

- Factory painting, all RAL colours, including metallic colours
- Factory painting, acc. to colour sample

1.2.4 Seals

The door is equipped with well designed sealings on all sides which gives the door its excellent sealing abilities.

1.2.4.1 Top seal

Installed on the frame at the top of the wall, the top seal provides continuous pressure on the top of the door leaves when the door is closed, ensuring maximum sealing.



1.2.4.2 Bottom seal

Installed on the bottom edge of each door leaf, the bottom seal provides continuous pressure on the floor, ensuring maximum sealing.



1.2.4.3 Seal between hinged leaves

Installed between each pair of door leaves. The flexible rubber material permits maximum movement of the door assembly and permanent sealing between the door leaves.

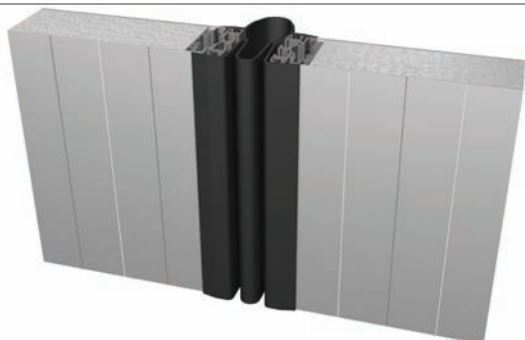

1.2.4.4 Side seal

Installed between the outer door leaves and the wall. The flexible rubber material permits maximum movement of the door assembly and provides permanent sealing between the door leaves and the walls.

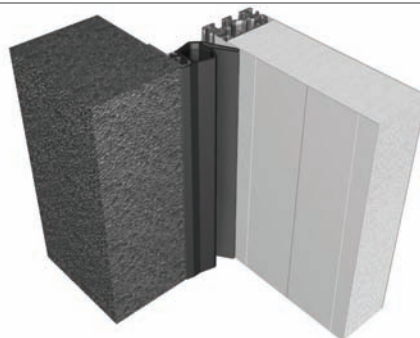

1.2.4.5 Safety edge seal

Installed on the edge of the two centre door leaves, the safety edge seal provides continuous pressure when the door is closed, ensuring maximum sealing. On electrical doors the sealing has a function as safety edge sealing.



1.2.4.6 Side cover

In combination with an installation frame the side cover works as a cover of and a protection from the frame hinges. Standard on all doors.

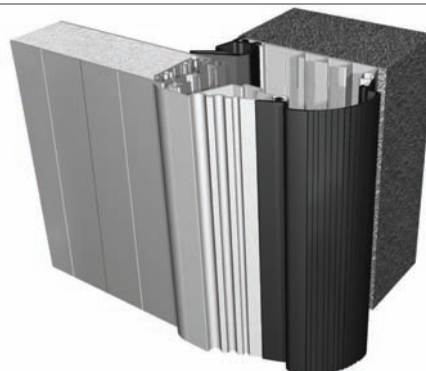

1.2.5 Windows

The frame construction allows windows in all door leaves. The light opening depends on the dimensions of the door leaf. Other materials than described below are available on request.

1.2.5.1 TG1

- Double-sided insulated hardened glass, rectangular, in plastic frame
- Light opening: 410 x 505 mm
- Window frame: black polycarbonate
- Window frames are burglar proof



1.2.5.2 TG2

- Double-sided insulated hardened glass, rectangular, in plastic frame
- Light opening: 410 x 1105 mm
- Window frame: black polycarbonate
- Window frames are burglar proof



1.2.5.3 TG5

- Double-sided insulated hardened glass, rectangular, in plastic frame
- Light opening: 245 x 555 mm
- Window frame: black polycarbonate
- Window frames are burglar proof



1.2.5.4 TG3 - only for passdoor

- Double-sided insulated hardened glass, rectangular, in plastic frame
- Light opening: 260 x 405 mm
- Window frame: black polycarbonate
- Window frames are burglar proof



1.2.5.5 TG4 - only for passdoor

- Double-sided insulated hardened glass, rectangular, in plastic frame
- Light opening: 260 x 1005 mm
- Window frame: black polycarbonate
- Window frames are burglar proof



1.2.6 Passdoor

For easy access the Crawford 521 folding door can be delivered with a passdoor. The passdoor can either be build in a door leaf or in a fixed section. It is also possible to have a door leaf as passdoor in cases where the door has a single leaf or an uneven numbers of leafs on one side.

1.2.6.1 Passdoor in doorleaf

The passdoor is designed with a handle that ensures easy opening and closing of the passdoor. The passdoor is not designed to be an emergency exit, as it has a threshold.

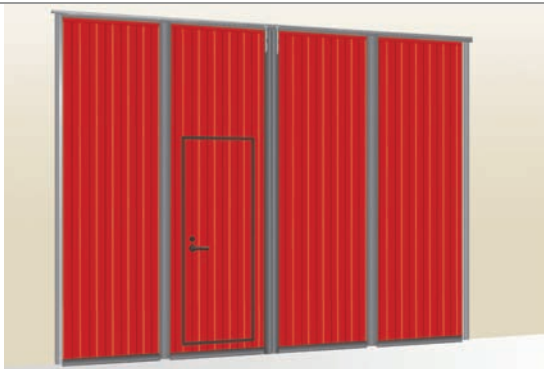

Features:

- Always opening outwards, min. 90 degrees opening
- Hinged left or right
- Seals in passdoor frame reduce air permeability.
- Integrated passdoor switch if electrically operated
- All commonly used cylinder locks are available: Euro, Kaba, Abloy, Assa.

1.2.6.2 Door leaf as a passdoor

The passdoor does not have a threshold and is delivered with a cremone lock as standard. The cremone handle ensures easy opening and closing of the passdoor. All commonly used cylinder locks are also available on request.



Features:

- No threshold
- Opening direction depends on installation side
- Only manually operated doors
- Cremone lock as standard
- All commonly used cylinder locks are available on request: Euro, Kaba, Abloy, Assa
- Max. recommended door height (DLH): Max. 4 m

1.2.7 Fixed sections

Fixed sections can advantageously fill space around new doors that are smaller than the wall opening. Fixed sections are available in top and side sections. Fixed sections are supplied in the same colour and construction as the door leaf.

A fixed section can be provided with a passdoor for two reasons: Safety and energy cost reduction.

- Safety: Putting a separate passdoor in a fixed section next to the industrial door separates pedestrian and vehicle traffic.
- Energy cost reduction: The opening space for frequent pedestrian traffic is minimized.

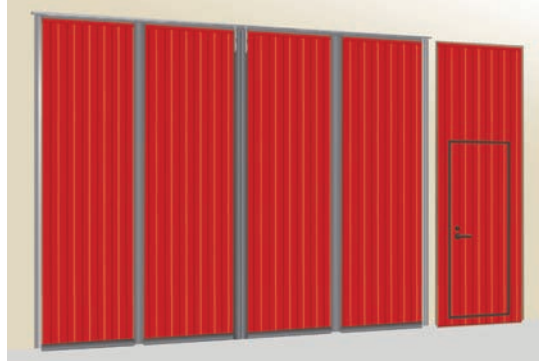



1.3 Manually operated door

The Crawford 521 folding door can be opened and closed by hand, using a solid, easy to grip handle and a cremone lock.

1.3.1 Handle

For manual operation the Crawford 521 folding door is supplied with a solid, easy to grip handle, installed in combination with an auto lock. The auto lock secures the door in the open position and must be released to close the door.



1.3.2 Locks

1.3.2.1 Cremone lock

The standard cremone lock has an inside handle and can lock the door without the use of a key. Optionally an outside cremone handle can be installed on the cremone lock.



1.3.2.2 Cylinder lock

For extra security a cylinder can be installed in combination with the cremone lock.

1.4 Electrically operated door

1.4.1 Electrical operation

The Crawford 521 folding door with a configuration 2+0, 0+2 or 2+2 can be supplied or upgraded with an electrical operating system. The system consists of a mechanical transmission unit with an electrical operator and a control unit. Electrical operation gives access to the full program of Access and Automation functions, that can fulfill many operational needs related to traffic type and frequency, door weight, and temperature control.

1.4.2 CDM9 FD Operating system

The CDM9 FD operating system is a combination of the CDM9 FD Operator and a 950 door control system.

1.4.2.1 CDM9 Operator

The CDM9 FD Operator is an electric motor that drives the door via a mechanical transmission unit. It can be retrofitted to an existing Crawford 521 folding door if the door is configured for electrical operation. The CDM9 FD Operator is installed directly on the mechanical transmission unit and does not require any special wall reinforcement. The transmission unit is built from anti-corrosive parts to ensure a long life, even in a humid environment.



Key features:

- Smooth and silent
- Soft start and stop
- Life time: 300.000 door cycles.

1.4.2.2 950 door control system Door control system

The standard 950 door control system is fully prepared for one or more physical upgrades from the entire range of automation systems. An automation system allows door operation by sensors or remote control.

This control unit contains a 3-digit diagnostics display that allows efficient troubleshooting and displays the number of door cycles completed. Together with the service indicator, this extra feature allows advanced maintenance planning for users where the door is an essential element of internal logistics.

Additional functions such as magnetic loop, photocells, radar and radio are available.





1.5 Access and automation

Crawford offers a wide range of functions that allows advanced opening and safety control.

1.5.1 Basic control functions

1.5.1.1 Interlocking



Developed for climate control or safety; If door A is open, door B cannot be opened. If door B is open, door A cannot be opened. An interlocked door can remember an up-command, if selected via a micro switch.
Circuit card installed in control unit.

1.5.2 External control functions

1.5.2.1 External push button box



An extra control box is installed outside the building or inside close to the door if the main control unit needs to be installed away from the door opening.
Installed on the inside or outside wall beside the door.

1.5.2.2 Pull-rope switch

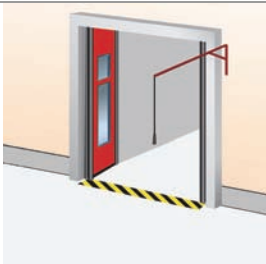

A pull-rope switch above the door opening can be operated from e.g. a forklift truck. Pulling the rope opens a closed door or closes an opened door.
Installed on the inside construction above the door.

1.5.2.3 Remote control



A hand-held radio transmitter allows door operation from a vehicle or any position within 50-100 meters from the receiver and aerial at the door. For closing, the door can be provided with a photocell beam.
Receiver installed in control unit, antenna installed on the wall beside the door.

1.5.3 Automatic control functions

1.5.3.1 Automatic closing

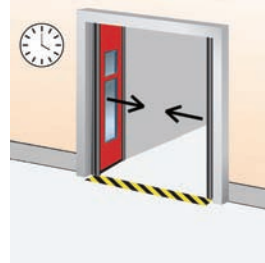

A programmable timer that closes the door after a specified time, counted from either the fully open position and/or from passing through the photocell beam.
Adjustable micro switches in control unit.

1.5.3.2 Magnetic loop



A sensor in the floor detects a metal object (usually forklift trucks, pallet trucks) and opens the door automatically. This is an ideal solution for frequent vehicle traffic.
Installed on the outside, inside or both sides of the door in the floor.

1.5.3.3 Photocell open door

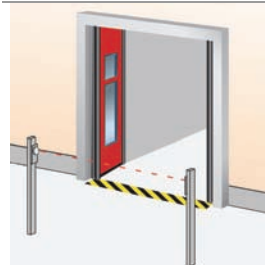

A set of photocells on pillars, on each side of the door. When a person or vehicle passes between the photocells, the beam is interrupted and the door opens.
Photocells installed on pillars, away from the door.

1.5.3.4 Radar

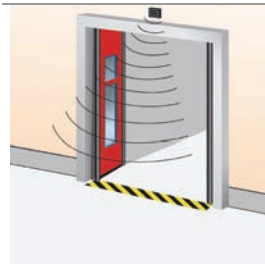

An infrared sensor above the door detects an object (person, vehicle) within a specified distance from the door and opens the door automatically. This is an ideal solution for frequent vehicle or personal traffic. Often combined with automatic closing.
Installed on the inside or outside wall above the door.

1.5.4 Safety functions

1.5.4.1 Safety edge

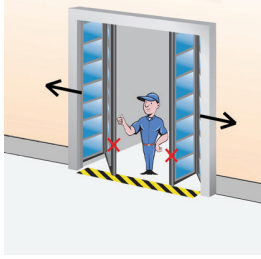

As a standard, all doors that have the impulse-open function or any form of automated closing, are equipped with a safety edge. The pneumatic sensor in the safety edge seal detects any obstruction between a closing door and reverses the door.
Installed in the safety edge seal.

1.5.4.2 Safety photocells 1-channel

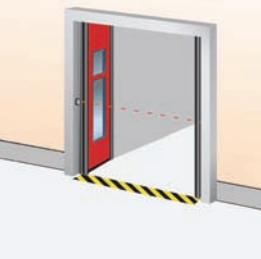

A set of a photocell transmitter and receiver is installed in the door opening. If the photocell beam is interrupted during closing, the door will stop in less than 30mm and reverse to the fully open position.
Installed in the door opening.

1.5.4.3 Safety photocells 2-channel

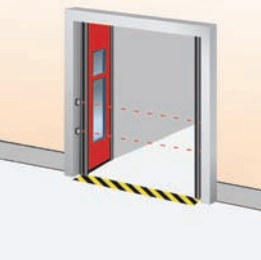

Two sets of photocell transmitter and receiver are installed in the door opening. If one or both photocell beams are interrupted during closing, the door will stop in less than 30mm and reverse to the fully open position.
Installed in the door opening.

1.5.4.4 Warning lights - Green

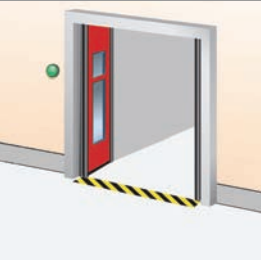

One or two green warning lights indicating the open position of the door by continuous light signal.
Installed on the inside and/or outside wall beside the door.

1.5.4.5 Warning lights - Red

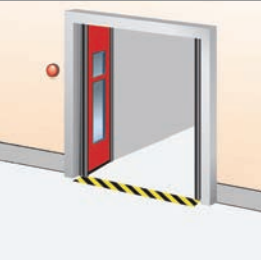

Two red warning lights giving information on the current door behaviour. Flashing light before or during door movement. Optional: Continuous light before and during door movement.
Installed on the inside and outside wall beside the door.

1.5.4.6 Traffic lights - Red & Green

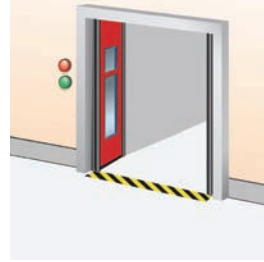

If traffic through a door needs to be directed; two red and two green traffic lights can be installed to indicate traffic direction. From the side where a vehicle is first detected to approach the door, the green traffic light comes on. The opposing side shows a red traffic light. Traffic from this direction must give way to the other. Usually installed in e.g. parking garages.
Installed on the inside and outside wall beside the door.

1.5.5 Additional functions

1.5.5.1 UPS battery backup



When mains failure cannot be permitted or an increased risk of mains failure is predicted, the UPS battery backup system can be installed to store enough energy for 10 door cycles.
Installed on the inside wall beside the door.

1.5.5.2 Relay box



A sealed connection box makes it possible to safely connect external high-voltage equipment.

1.6 Monitoring systems

As an option on all our products, a Crawford Monitoring System can be installed. This system helps to ensure efficiency and security in daily operations. All doors or docking stations are connected to the Monitoring System's server, which gives the opportunity to supervise, monitor and report a wide variety of aspects in a facility.

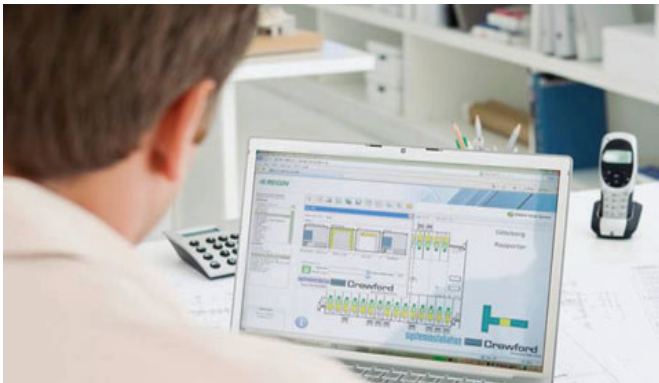

1.6.1 Saving energy

A monitoring system reduces energy costs and contributes to a better environment. Energy is lost every time a door is open. If a door is open when no truck is at the bay, even more energy is lost.

A Crawford Monitoring System automatically ensures that no door will open unless there is a truck at the bay and even set it to close when there an activity is delayed.

1.6.2 Security enhancement

Closing and locking doors is an obvious daily routine. However, checking this manually can be time consuming in a busy facility.

A Crawford Monitoring System can automatically ensure that all doors are closed and locked when they need to be. It can also activate all doors and locks from its remote location, and give a real-time overview of the building's situation.

1.6.3 Dock management

A good way to increase throughput and thereby efficiency at a logistics facility is to reduce the time of having no truck – or the wrong truck – at a loading bay.

A Crawford Monitoring System makes visible – in real-time – which bays are occupied or free, and for how long. It makes it possible to reserve bays for docking activities and to inform drivers via SMS. Since it incorporates information from cameras and other inputs (RFID, card readers, etc.), the system stays updated in real-time.

1.6.4 Facility management

The Crawford Monitoring System gives a real-time service status for all your door and docking equipment. If an error code occurs, the Crawford service organisation is automatically notified, and will respond quickly. Other maintenance information can easily be integrated, further reducing the overall costs.

2. Specifications

2.1 Dimensions

2.1.1 Daylight width and daylight height

The standard Crawford 521 folding door is delivered in the following size range:

Standard door sizes

	Daylight width (DLW)	Daylight height (DLH)
Min.:	1020 mm	2000 mm
Max.:	7590 mm	6000 mm

Other sizes available on request.

2.1.2 Section sizes

Leaf width (SW):	553 - 1253 mm*
Thickness:	50 mm

*The total width of the door is equally divided over the leaves at interval steps of 25 mm.

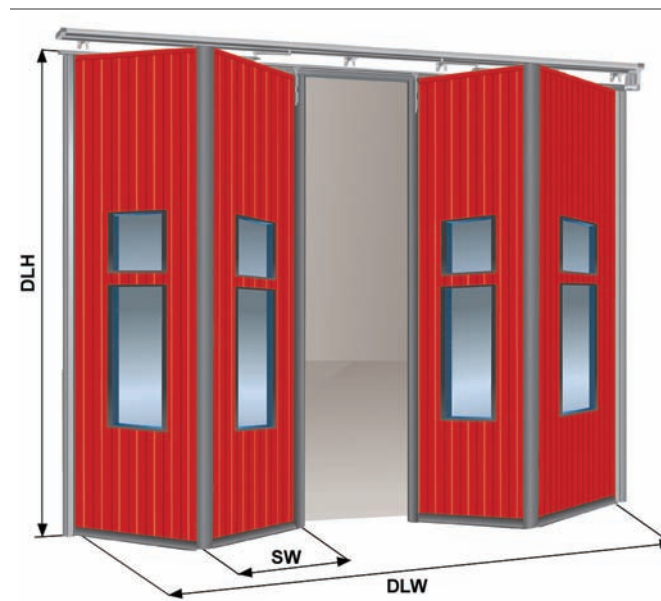

2.2 Configurations

Configuration	Dimensions (DLW)	Manual door	Electric door	Door assembly
0 + 2	1020 mm - 2460 mm	■	■	
1 + 2	1640 mm - 3750 mm	■		
1 + 3	2200 mm - 5020 mm	■		
2 + 0	1020 mm - 2460 mm	■	■	
2 + 1	1640 mm - 3750 mm	■		
2 + 2	2200 mm - 5020 mm	■	■	
2 + 3	2760 mm - 6320 mm	■		
3 + 1	2200 mm - 5020 mm	■		
3 + 2	2760 mm - 6320 mm	■		
3 + 3	3393 mm - 7590 mm	■		

■ Available

* Other configurations available on request

2.3 Passdoor

2.3.1 Passdoor in doorleaf

Passdoor size limitations

Type	Passdoor width [mm]	Min leaf width [mm]	Windows
Passdoor 600	595	878	TG3/TG4/TG5
Passdoor 800	820	1103	TG3/TG4/TG5

Specifications

Lock:	Depends on market
Threshold height:	115 mm incl. bottom seal

This passdoor is only available in the second door leaf from the wall.

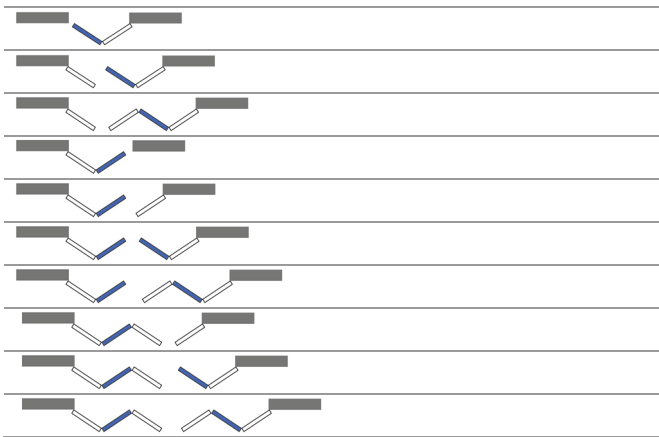

2.3.2 Doorleaf as a passdoor

Passdoor size limitations

Minimum height	2000 mm
Maximum daylight height	3300 mm
Max. recommended door height (DLH)	Max. 4 m.

Specifications

Threshold height:	None
Handle/lock	Standard: Cremone lock Optional: Lock with roller latch
Lock	Depends on market

This passdoor is only available as the first or third door leaf from the wall.

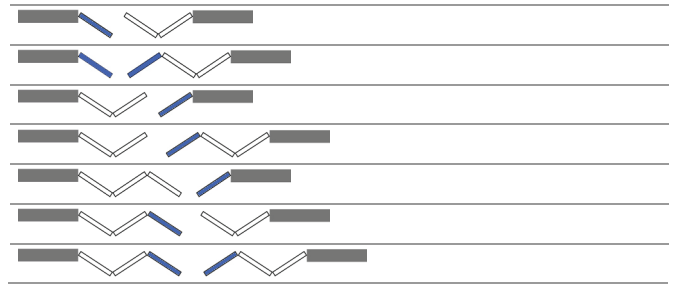

2.4 Door operation

2.4.1 Selection guidelines for operation type

Door size m ²	Openings / day			
	1-5/day	5-10/day	10-15/day	>25/day
0 – 10	<input type="checkbox"/> / <input checked="" type="checkbox"/>	<input type="checkbox"/> / <input checked="" type="checkbox"/>	<input checked="" type="checkbox"/> / <input checked="" type="checkbox"/>	<input checked="" type="checkbox"/> / <input checked="" type="checkbox"/>
10 – 20	<input type="checkbox"/> / <input checked="" type="checkbox"/>	<input checked="" type="checkbox"/>	<input checked="" type="checkbox"/> / <input checked="" type="checkbox"/>	<input checked="" type="checkbox"/> / <input checked="" type="checkbox"/>
> 20 - 42	<input checked="" type="checkbox"/>	<input checked="" type="checkbox"/>	<input checked="" type="checkbox"/> / <input checked="" type="checkbox"/>	<input checked="" type="checkbox"/> / <input checked="" type="checkbox"/>
> 42*	<input type="checkbox"/>	<input type="checkbox"/>	<input type="checkbox"/>	<input type="checkbox"/>

- Manual operation
- Electrical operation
- Automated operation

2.4.2 950 door control system functions

Functions	950 FD
	
Open (by impulse)	<input checked="" type="checkbox"/>
Stop	<input checked="" type="checkbox"/>
Close (by impulse)	<input checked="" type="checkbox"/>
Safety edge	<input checked="" type="checkbox"/>
Open function	<input checked="" type="checkbox"/>
One button function	<input checked="" type="checkbox"/>
Display (diagnostics)	<input checked="" type="checkbox"/>
Service indicator	<input checked="" type="checkbox"/>

2.4.3 950 door control system - Selection guidelines for automation

The “Automation D-kits“ are packages of common combinations. These kits can also be supplemented by “additions to D-kits“.

Automation D-kits	D1	D2	D3	D4	D5	D6	D7
Interlocking	<input checked="" type="checkbox"/>	<input checked="" type="checkbox"/>	<input checked="" type="checkbox"/>	<input checked="" type="checkbox"/>	<input checked="" type="checkbox"/>	<input checked="" type="checkbox"/>	<input checked="" type="checkbox"/>
Magnetic loop		<input checked="" type="checkbox"/>		<input checked="" type="checkbox"/>			<input checked="" type="checkbox"/>
Traffic lights - Green + Red					<input checked="" type="checkbox"/>	<input checked="" type="checkbox"/>	
Warning lights - Red	<input checked="" type="checkbox"/>			<input checked="" type="checkbox"/>			
Additions to D-kits							
Warning lights - Green			<input type="checkbox"/>				
Relay box	<input type="checkbox"/>	<input type="checkbox"/>	<input type="checkbox"/>	<input type="checkbox"/>	<input type="checkbox"/>	<input type="checkbox"/>	<input type="checkbox"/>
Radar	<input type="checkbox"/>	<input type="checkbox"/>	<input type="checkbox"/>	<input type="checkbox"/>	<input type="checkbox"/>	<input type="checkbox"/>	<input type="checkbox"/>

Standard
 Option / Available

The following options can be individually selected to add functionality to the control unit.

Functions optional	950 FD
	
Complete kits	
Automation D-kits	<input type="checkbox"/>
Basic control functions	
Interlocking	<input type="checkbox"/>
External control functions	
External push-button box	<input type="checkbox"/>
Pull-rope switch	<input type="checkbox"/>
Remote control open/stop/close	<input type="checkbox"/>
Remote control 1-button function	<input type="checkbox"/>
Automatic control functions	
Automatic closing	<input type="checkbox"/>
Photocell open door	<input type="checkbox"/>
Safety functions	
Safety photocells 1-2	<input type="checkbox"/>
Additional functions	
UPS Battery backup	<input type="checkbox"/>
Relay box	<input type="checkbox"/>

Standard
 Option / Available

3. CEN Performance

The following tests have been carried out by the Swedish National Testing and Research Institute in Borås. For more detailed information and values, see ITT report: 0402-CDP-397301

3.1 Lifetime expectation

300.000 door cycles or 20 years (in a normal industrial environment and with the recommended yearly service check)

3.2 Resistance to windload

EN12424	Manually operated door	Electrically operated door
DLW 7590 mm x DLH 6000 mm	Class 2	-
DLW 5000 mm x DLH 6000 mm	Class 2	Class 3
DLW 3500 mm x DLH 3000 mm	Class 3	Class 5

3.3 Resistance to water penetration

EN12425	Without passdoor
Test result	Class 3

3.4 Air permeability

EN12426	Without passdoor
Test result	Class 2

3.5 Thermal transmittance

EN12428	Double Acrylic/Glass
Thermal transmittance	1,7 W/m ² K*

* These values are calculated values for a complete, installed, door of 4000 x 4000 mm and have to be confirmed by an official test.

3.6 Operating forces and safe openings

EN12453 & EN12604	Crushing force N	Crushing force N	Crushing force N
Opening gap mm	200 mm from lateral border right from outside	In the middle of the door opening	200 mm from lateral border left from outside
50 N	passed	passed	passed
300 N	passed	passed	passed

The crushing force is the force needed for the safety edge to be activated. The maximum force allowed, according to EN12453 safety in use of power operated doors, is 400 N within a period of time of 0.75 s.

4. Building and space requirements

4.1 Building preparations

4.1.1 Installation preparations

The Crawford 521 folding door is shipped in parts and installed on-site. All necessary installation material is included. For every building type Crawford offers specific installation kits to install the door in the building facade. To install the door a solid installation surface is required.

1. Steel
2. Wood
3. Brick & Concrete

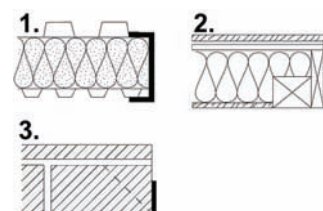

4.1.2 Electrical preparations

The manually operated door needs no electrical supply.

For an electrically operated door, the following environment criteria and electrical supplies are required for the operator to function properly:

	CDM9 FD
Voltage supply: (+/- 10%)	230V AC 1-phase 50/60Hz
Power supply:	0,5 kW
Degree of protection:	IP55, excl. connector IP 44
Max. allowed total weight of door leaves:	750 kg
Working temperature range:	-20 °C to +60 °C*
Operating factor:	ED = 30% S3 10 min. intermittent
Installation preparations:	-

*) Normal opening speed in temperatures down to -8°C. In the temperature range -8 °C to -20 °C the opening speed is reduced during the first cycle in a two-hour period to prolong the operator's lifetime. An optional heating element is available for a working range down to -30 °C

4.2 Space requirements

4.2.1 Dimension terminology

DLW	= Daylight Width	The width of the clear opening.
DLH	= Daylight Height	The height of the clear opening.
OH	= Headroom	The space required above the daylight height.
SL	= Side space Left	The space required beside the daylight width.
SR	= Side space Right	The space required beside the daylight width.
D	= Depth	The space required to move the door leaves.

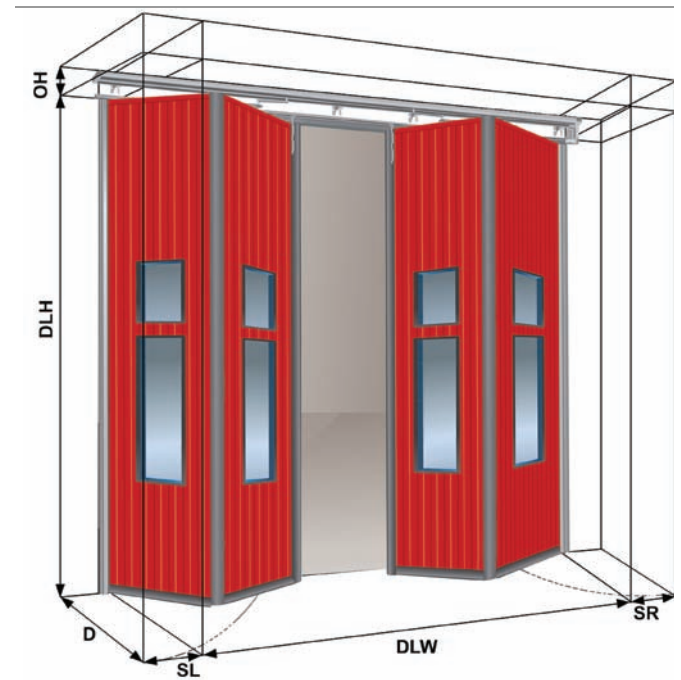

4.2.2 Space requirements manual doors

Configuration	SL	SR	OH
0+2	175	185-285	150
2+2	185-285	185-285	150
2+0	185-285	175	150

* Dimensions in mm.

4.2.3 Space requirements electrically operated doors

No plastic cover on operator*

Configuration	Operator position left			Operator position right			Operator position center		
	SL	SR	OH	SL	SR	OH	SL	SR	OH
0+2	175	350	235	175	550	235	N.A.	N.A.	N.A.
2+2	490	350	235	350	550	235	350	350	375
2+0	490	175	235	350	215	235	N.A.	N.A.	N.A.

* Dimensions in mm.

With plastic cover on operator*

Configuration	Operator position left			Operator position right			Operator position center		
	SL	SR	OH	SL	SR	OH	SL	SR	OH
0+2	175	350	270	175	575	270	N.A.	N.A.	N.A.
2+2	510	350	270	350	575	270	350	350	395
2+0	510	175	270	350	240	270	N.A.	N.A.	N.A.

* Dimensions in mm.

4.2.4 Depth

The minimal required depth is the width of a door leaf (SW 553-1253mm) + 180 mm

5. Service



These keys open doors to better business

Regardless of their function, age or manufacturer, your industrial doors and dock loading systems have an important role in the flow of your business. That's why it makes sense to plan their maintenance long before the need for service occurs.

A Key Customer Service agreement from Crawford is your best assurance of safe and trouble-free door and dock operation. By becoming a key customer, you not only reduce the risk of breakdowns, but also guarantee compliance with local regulations and the new harmonised EU standards. You also ensure that your doors and dock loading systems retain their classifications for wind load, air permeability, water penetration and more.

Four types of Key Customer Service agreement – Green, Yellow, Blue and Red – allow us to tailor our service to your specific needs. Based on the role of your doors and dock loading systems, and the intensity with which you use them, you receive service that provides the perfect balance of economy, safety and security.

Best of all, the maintenance is performed by Crawford's renowned team of service technicians. As a qualified specialist in industrial doors and dock loading systems, we have the knowledge and skills to service any door or dock, regardless of its type, age or manufacturer. With Crawford as a single source for all your door and docking equipment brands, you can easily reduce costs while increasing equipment availability.

6. Index

9

950 door control system - Selection guidelines for automation.....	18
950 door control system Door control system	12
950 door control system functions.....	18

A

Access and automation	13
Additional functions	14
Air permeability	19
Automatic closing	13
Automatic control functions.	13

B

Basic control functions.....	13
Bottom seal.....	8
Building and space requirements	20
Building preparations	20

C

CDM9 FD Operating system..	12
CDM9 Operator	12
CEN Performance	19
Colours.....	7
Configurations.....	16
Construction	7
Copyright and Disclaimer Notice.....	2
Cremona lock.....	11
Cylinder lock.....	11

D

Daylight width and daylight height	16
Depth	21
Description.....	6
Dimension terminology	21
Dimensions	16
Dock management.....	15
Door leaf as a passdoor	10
Door leaves	7
Door operation.....	17
Doorleaf as a passdoor	17

E

Electrical operation	12
Electrical preparations	20
Electrically operated door.....	12
External control functions	13
External push button box	13

F

Facility management.....	15
Features.....	3
Fixed sections	10

G

General.....	6
--------------	---

H

Handle	11
--------------	----

I

Installation preparations.....	20
Interlocking.....	13

L

Lifetime expectation	19
Locks.....	11

M

Magnetic loop.....	13
Manually operated door	11
Material.....	7
Monitoring systems	15

O

Operating forces and safe openings	19
Optional colours	7
Options.....	6

P

Passdoor	10, 17
Passdoor in doorleaf.....	10, 17
Performance.....	3
Photocell open door.....	13
Pull-rope switch	13

R

Radar	13
Relay box.....	14
Remote control	13
Resistance to water penetration.....	19
Resistance to windload	19

S

Safety edge	14
Safety edge seal	8
Safety functions	14
Safety photocells 1-channel .	14
Safety photocells 2-channel .	14
Saving energy.....	15
Seal between hinged leaves...	8
Seals.....	8
Section sizes	16
Security enhancement	15
Selection guidelines for operation type	17
Service.....	22
Side cover	8
Side seal.....	8
Space requirements	21
Space requirements electrically operated doors.....	21
Space requirements manual doors.....	21
Specifications.....	16
Standard	6
Standard colours	7

T

Technical facts.....	3
TG1.....	9
TG2.....	9
TG3 - only for passdoor	9
TG4 - only for passdoor	9
TG5.....	9
Thermal transmittance	19
Top seal	8
Traffic lights - Red & Green ..	14

U

UPS battery backup.....	14
-------------------------	----

W

Warning lights - Green	14
Warning lights - Red	14
Windows.....	9

Crawford is a leading ASSA ABLOY brand focusing on automated entrance solutions for efficient movement of vehicles and goods. With a complete portfolio of door and docking solutions, an extensive service offer and professional advice, we help customers ensure convenient, safe, secure and energy saving operations around-the-clock. Crawford is represented in more than 30 countries and is part of ASSA ABLOY Entrance Systems, which also includes the globally recognized Megadoor and Besam brands.

www.crawfordsolutions.com



Crawford

ASSA ABLOY