

Crawford 9120 High speed door

Product datasheet



Copyright and Disclaimer Notice

Although the contents of this publication have been compiled with the greatest possible care, ASSA ABLOY Entrance Systems cannot accept liability for any damage that might arise from errors or omissions in this publication. We also reserve the right to make appropriate technical modifications/replacements without prior notice.

No rights can be derived from the contents of this document.

Color guides: Color differences may occur due to different printing and publication methods.

ASSA ABLOY, Crawford, Megadoor and hafa, as words and logos, are examples of trademarks owned by ASSA ABLOY Entrance Systems or companies within the ASSA ABLOY Group.

Copyright © ASSA ABLOY Entrance Systems 2006-2011

No part of this publication may be copied or published by means of scanning, printing, photocopying, microfilm or any other process whatsoever without prior permission in writing by ASSA ABLOY Entrance Systems.

All rights reserved



Technical facts

Features

Area of use:	Inside
Structure:	Galvanized steel
Max size: (W x H)*	11000 mm x 5500 mm
Operating speed:	Opening: up to 0,8 m/s ** Closing: 0,4 m/s
Wind load resistance	Class 1 (300 N/m ²)
Colours:	8 colours - white, yellow, green, orange, red, grey, black, blue
Safety:	Photocells in side columns Flexible soft bottom edge including wireless safety edge Break-away and self-repair function
Options:	Different vision options are available. Colour of drum cover, side column cover, motor cover.

* Other sizes available on request

** Depending on size

Performance

Operating speed:	Opening: 0,8 m/sec Closing: 0,4 m/sec
Wind load resistance	Class 1 (300 N/m ²)
Water penetration	Class 1 (30 N/m ²)
Air permeability	Class 1 (24 m ³ /m ² /h at 50 Pa)
Thermal transmittance	6,02 W/(m ² K)
Lifetime expectations:	1.000.000 cycles

Contents

Copyright and Disclaimer Notice	2
Technical facts.....	3
Features.....	3
Performance.....	3
1. Description.....	5
1.1 General	5
1.1.1 Standard	5
1.1.2 Options	5
1.2 Door curtain	6
1.2.1 Construction	6
1.2.2 Material	6
1.2.3 Colours.....	6
1.2.4 Windows.....	6
1.2.5 Self repair system.....	6
1.2.6 Bottom edge.....	6
1.3 Side columns.....	7
1.3.1 General	7
1.4 Header box	7
1.4.1 Fabric roll	7
1.4.2 Covers.....	7
1.5 Operating system	8
1.5.1 General	8
1.5.2 Operator	8
1.5.3 Door drive system	8
1.5.4 Control unit	8
1.5.5 Chain hoist.....	8
1.5.6 Access and automation	9
1.5.7 Monitoring systems	12
2. Specifications.....	13
2.1 Daylight width and height.....	13
2.2 Fabric specifications	13
2.3 Windows.....	13
2.3.1 Required Daylight Width.....	13
2.3.2 Required Daylight Height.....	13
3. CEN Performance	14
4. Building and space requirements.....	15
4.1 Building preparations.....	15
4.1.1 Installation preparations	15
4.1.2 Electrical preparations.....	15
4.2 Space requirements.....	16
5. Service	17
6. Index	18

1. Description

1.1 General

The Crawford 9120 high speed door is designed for interior use in medium-sized heavy-duty operations. It protects your environment against draught, humidity, dust and dirt. With fast opening and closing speed, the door improves your traffic flow, provides employee comfort, and saves energy.

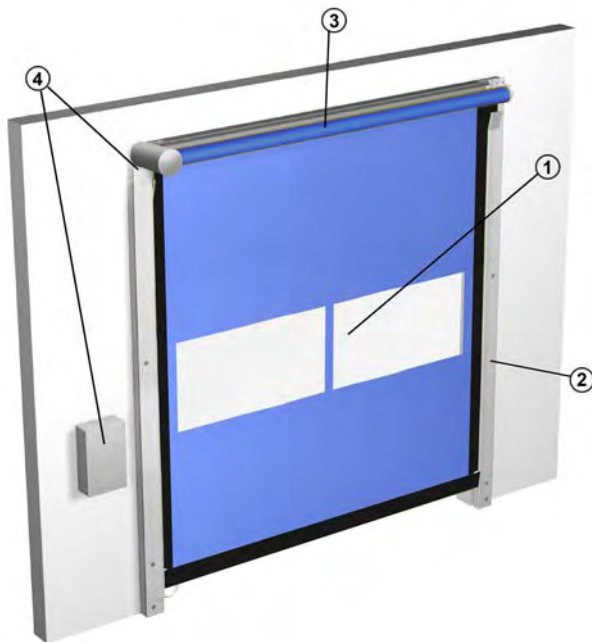

The Crawford 9120 High speed door has 4 primary parts:

1. Door curtain
2. Side columns
3. Header box
4. Operating system

1.1.1 Standard

The Crawford 9120 high speed door is supplied with the following specifications as standard:

Door curtain:	900 g/m ² coloured PVC Self repairing function
Frame:	Galvanized steel
Safety:	Photocells in side columns Flexible soft bottom edge including wireless safety edge Break-away and self-repair function
Operation:	Operator + control unit
Colours:	8 colours - white, yellow, green, orange, red, grey, black, blue

1.1.2 Options

Crawford provides a wide range of options and accessories to customise the Crawford 9120 high speed door to any customer's needs.

Header box:	Galvanized steel drum cover Galvanized steel operator cover
Side column:	Galvanized steel side column covers
Operation:	Access and Automation Crawford Monitoring System
Windows:	Small windows

1.2 Door curtain

1.2.1 Construction

The door curtain is constructed from one single piece of PVC fabric. The door curtain rolls up above the door opening and requires little space.

Top

The top of the fabric is connected to a fabric roll, located in the header box above the door opening.

Bottom

The flexible bottom edge of the door curtain does not contain any stiffeners, making the door curtain completely safe as the curtain moulds itself in case a person is trapped below the closing door.

Side

The left and right sides of the door curtain are constructed with a patented retaining strap. If the door is hit by a vehicle, a part of this retaining strap is pulled out of the side column. The self repair function acts as a zipper to put the retaining strap back in the side column.







1.2.2 Material

Fabric type

- 900 g/m² coloured PVC
- High resistance

1.2.3 Colours

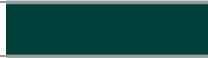
The Crawford 9120 high speed door is available in 8 fabric colours. The RAL-colours are as close as possible to the official RAL HR collection. Max. deviation is 1,0 DE.

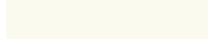
	RAL 1003
	RAL 2004
	RAL 3000
	RAL 5002
	RAL 6005
	RAL 7035
	RAL 9005
	RAL 9010

1.2.4 Windows

To increase the admission of daylight or to improve the visibility, the door curtain can be equipped with windows. Windows have fixed sizes and are located on a pre-defined grid.



1.2.5 Self repair system

Crawford high speed doors are equipped with an automatic repair system. If a door is hit by a vehicle during operation, the resistant door curtain absorbs the impact and releases itself from its side guides without damage. The door reinserts itself automatically within the next open and close cycle. This unique feature makes the door crash-resistant without sustaining damage, reducing production downtime and maintenance.



1.2.6 Bottom edge

The bottom edge is a flexible bag that contains a wireless safety edge. When the door is hit by a vehicle, the curtain moulds and the contacts within make a closed circuit. The wireless signal is then sent to the operator to stop the door movement immediately.



1.3 Side columns

The side columns guide the door curtain up and down. This guidance is a plastic-to-plastic connection, which makes lubrication essential.

1.3.1 General

The side columns are part of the frame that also contains the header box. This frame is made of 3 mm thick galvanized steel tubes. The side columns are connected directly to the wall.

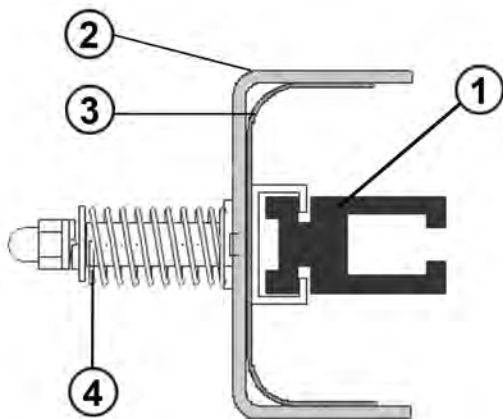

1. Low-friction polyethylene side guide inside a steel rail
2. Galvanized steel structure. U-channel 80 mm x 40 mm x 3 mm
3. Flexible rubber seal
4. Tension spring

1.4 Header box

1.4.1 Fabric roll

The fabric roll is installed in the header box above the door curtain. Its function is to roll up the door curtain by means of a counterweight. A gear drive system forces the door curtain up and down the tracks.

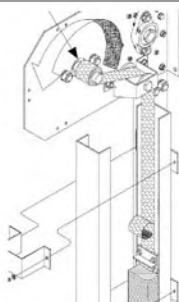

1.4.2 Covers

For use in dusty and dirty environments or for aesthetical reasons, an optional header box cover is available to enclose the fabric roll and/or the operator. Also the side columns can be equipped with covers.

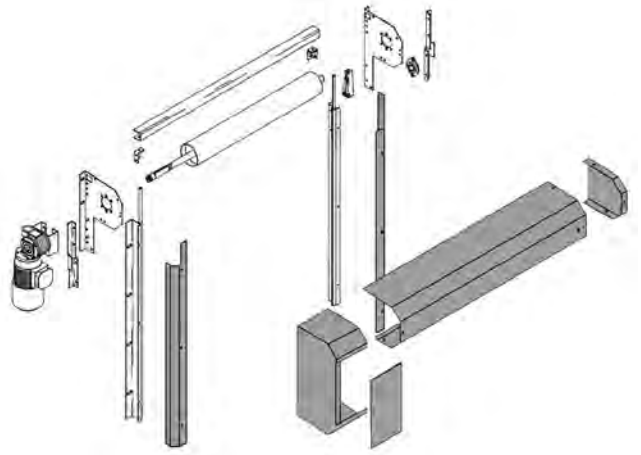

1.5 Operating system

1.5.1 General

The Crawford 9120 high speed door is always operated electrically. The operating system is a combination of an operator and a control unit. The operator opens and closes the door with an electric engine. The operator secures a safe closing speed with a soft start and stop.

1.5.2 Operator

Exceptional reliability and smooth operation is ensured by a motor driven by a frequency inverter. This technology ensures a soft start and stop, which increases the longevity of the motor considerably. It also allows faster opening/closing speed. This motor delivers reliable operations around-the-clock. The operator is always combined with a control unit.

The operator drives the fabric roll to open or close the door. In case of a main supply failure, the operator can be disconnected and the door can be opened or closed manually using the hand crank.

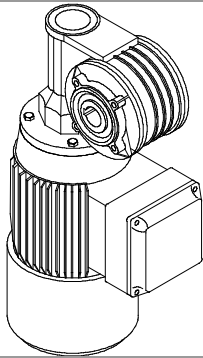

1.5.3 Door drive system

The high speed doors are equipped with a unique door drive system. This system eliminates the need for ballast in the door curtain or tension straps. This gear driven system consists of a pinion on the drive shaft that forces the lateral retaining straps up or down the tracks. This ensures that even under high pressure difference the door will be fully closed.

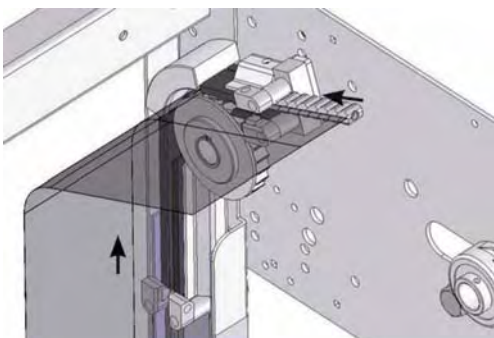

1.5.4 Control unit

The control unit is installed beside the door. It has impulse UP and DOWN buttons, an emergency stop mushroom button and a mechanical mains switch.

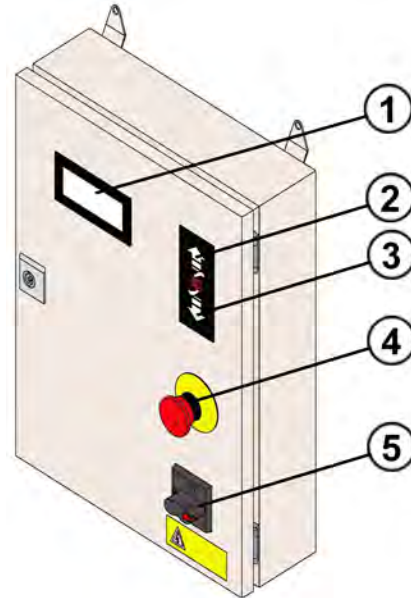

1. Display
2. UP button
3. DOWN button
4. Emergency stop
5. Mechanical main switch

1.5.5 Chain hoist

A chain hoist makes it possible to manually operate the door, e.g. during a power failure. When the electrical operation is in use, the chain hoist is disconnected. When manual operation is required, pulling a string will release the motor brake, allowing the drum to rotate freely, using the chain hoist.

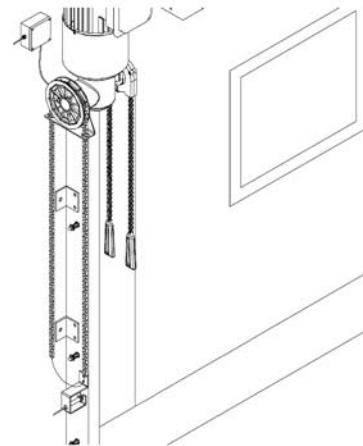



1.5.6 Access and automation

Crawford offers a wide range of functions that allow advanced opening and safety control.

1.5.6.1 Basic control functions

Interlocking



Developed for climate control or safety; If door A is open, door B cannot be opened. If door B is open, door A cannot be opened. An interlocked door can remember an up-command, if selected via a micro switch.
Circuit card Installed in control unit.
Optionally an external locked switch can be installed to deactivate it.

- Function Interlock operating (switch interlock ON/OFF delivered with priority door)
- Switch interlock on/off (requires interlock function)
- Switch interlock on/off with key (requires interlock function)

Airlock

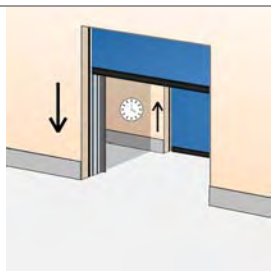

Developed for climate control or safety: Other than the interlock, door B will open automatically when door A is closed.
Circuit card Installed in control unit.
Optionally an external locked switch can be installed to deactivate it.

Reduced opening

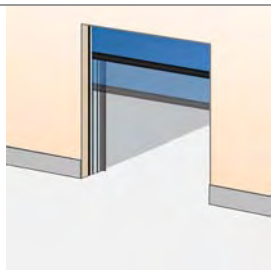

When people pass through the door, it may be unnecessary to fully open a door. A manual (pedestrian) command can trigger a reduced door opening, while a radar or magnetic loop still triggers a full door opening.
Pre-fitted micro-switch to be activated in control unit.

- Function Two opening heights I/II with manual selection (switch included)
- Function Two opening heights I/II with automatic selection (2 different opening impulses)

1.5.6.2 External control functions

External push button box

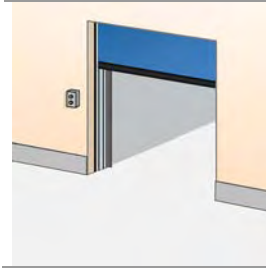

An extra control box is installed outside the building or inside close to the door if the main control unit needs to be installed away from the door opening. Usually combined with reduced opening.
Installed on the inside or outside wall beside the door.

Pull-rope switch

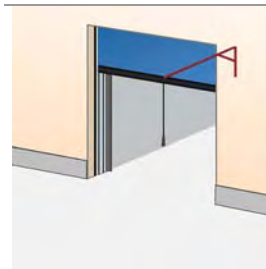

A pull-rope switch above the door opening can be operated from e.g. a forklift truck. Pulling the rope opens the door.
Installed on the inside construction above the door.

- Pull down switch complete 5 m cord
- Pull switch bracket in galvanised steel – L 3000 mm
- Pull switch bracket in painted steel – L 3000 mm
- Pull switch bracket in stainless steel – L 3000 mm

Remote control



A hand-held radio transmitter allows door operation from a vehicle or any position within 50-100 meters from the receiver and aerial at the door.
Receiver installed in control unit, antenna installed on the wall beside the door.

1.5.6.3 Automatic control functions

- Function Auto/Manual (includes switch on the control box)
- Function Manual closing with opening/closing using a common manual command (e.g. one single pull rope opens and closes the door)
- Function Manual closing with separate impulse (e.g. 2 buttons ▼▲)

Magnetic loop

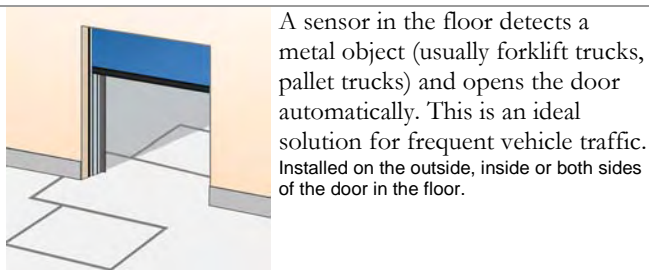

Radar

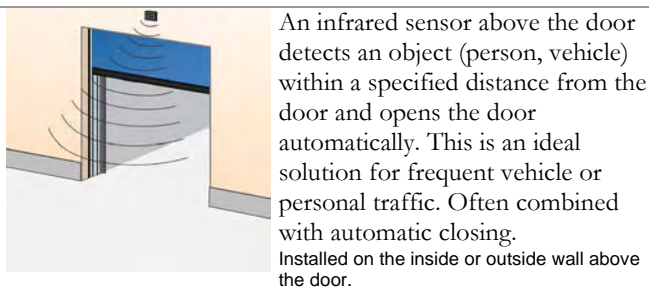

Photocell open door

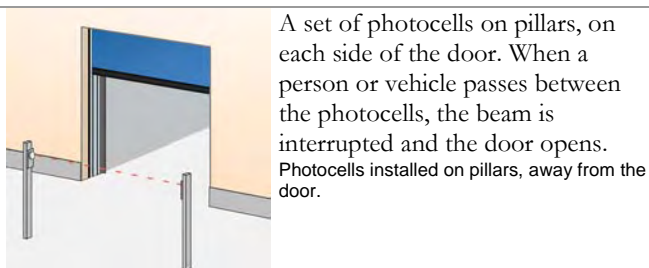

Automatic closing (standard)

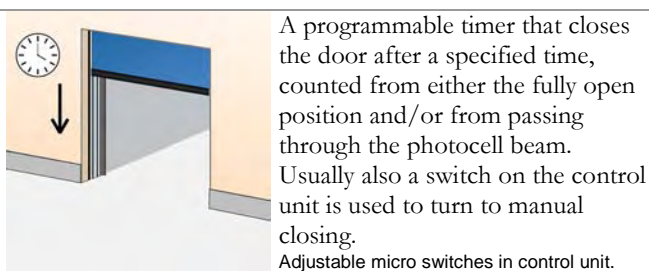

1.5.6.4 Safety functions

Wireless safety edge (standard)

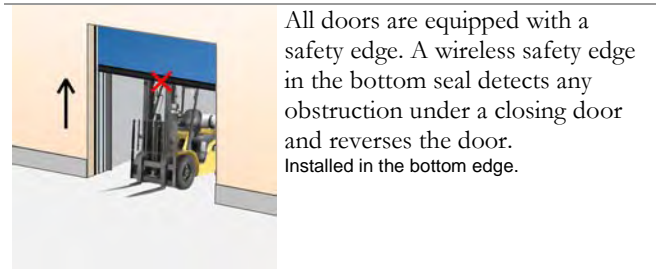

Safety photocells 1-channel (standard)

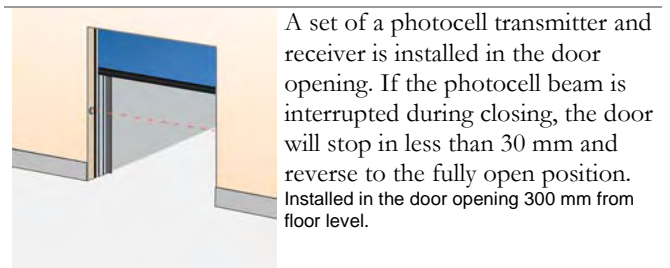

Warning lights - Red

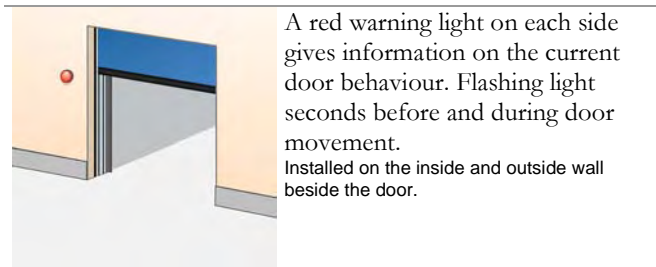

Acoustic signal

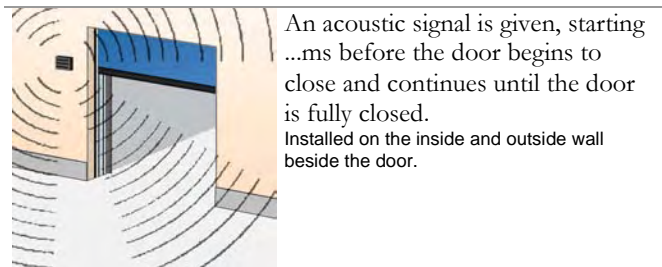

- Acoustic signal 24VAC 80 dB at 1 meter (horn when door is moving)



1.5.6.5 Lights

- Standard function flashing light
- Standard function flashing light with pre-warning before closing and opening

Warning lights - Orange

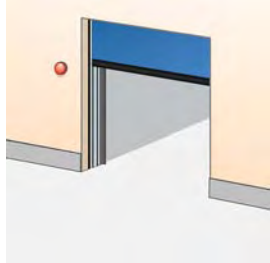

An orange warning light on each side gives information on the current door behaviour. Flashing light seconds before and during door movement.
Installed on the inside and outside wall beside the door.

Warning lights - Green

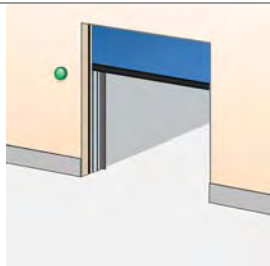

A green warning light installed on each side of the door indicating the open position of the door by continuous light signal.

Traffic lights - Red & Green

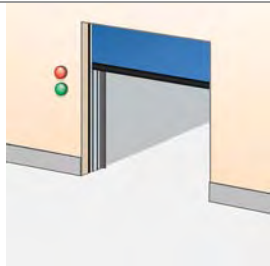

If traffic through a door needs to be directed; two red and two green traffic lights can be installed to indicate traffic direction. From the side where a vehicle is first detected to approach the door, the green traffic light comes on. The opposing side shows a red traffic light. Traffic from this direction must give way to the other. Usually installed in e.g. parking garages.
Installed on the inside and outside wall beside the door.

1.5.6.6 Additional functions

UPS battery backup

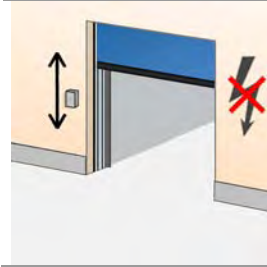

In case of main supply failure or emergency situations, it may be necessary to be able to open the door. The UPS battery stores enough power for one emergency opening cycle.
Installed on the inside wall beside the door.

- Kit UPS Interface, automatic opening in case of power failure
- Kit UPS Interface, semi-automatic in case of power failure

1.5.7 Monitoring systems

As an option on all our products, a Crawford Monitoring System can be installed. This system helps to ensure efficiency and security in daily operations. All doors or docking stations are connected to the Monitoring System's server, which gives the opportunity to supervise, monitor and report a wide variety of aspects in a facility.



1.5.7.1 Saving energy

A monitoring system reduces energy costs and contributes to a better environment. Energy is lost every time a door is open. If a door is open when no truck is at the bay, even more energy is lost.

A Crawford Monitoring System automatically ensures that no door will open unless there is a truck at the bay and even set it to close when there an activity is delayed.

1.5.7.2 Security enhancement

Closing and locking doors is an obvious daily routine. However, checking this manually can be time consuming in a busy facility.

A Crawford Monitoring System can automatically ensure that all doors are closed and locked when they need to be. It can also activate all doors and locks from its remote location, and give a real-time overview of the building's situation.

1.5.7.3 Dock management

A good way to increase throughput and thereby efficiency at a logistics facility is to reduce the time of having no truck – or the wrong truck – at a loading bay.

A Crawford Monitoring System makes visible – in real-time – which bays are occupied or free, and for how long. It makes it possible to reserve bays for docking activities and to inform drivers via SMS. Since it incorporates information from cameras and other inputs (RFID, card readers, etc.), the system stays updated in real-time.

1.5.7.4 Facility management

The Crawford Monitoring System gives a real-time service status for all your door and docking equipment. If an error code occurs, the Crawford service organisation is automatically notified, and will respond quickly. Other maintenance information can easily be integrated, further reducing the overall costs.



2. Specifications

2.1 Daylight width and height

The standard Crawford 9120 high speed door is delivered in the following size range:

Standard door sizes*		
	Daylight width	Daylight height
Min.:	5500 mm	2000 mm
Max.:	11000 mm	5500 mm

* Other sizes may be available on request

2.2 Fabric specifications

	Coloured fabric	Vision panel
Material	Reinforced PVC	PVC
Thickness	0,8 mm	2,0 mm
Weight	0,9 kg / m ²	2,5 kg / m ²
Tensile strength (kN/5cm)	4,0 L / 3,5 W	1,6
Tearing resistance	600 N (DIN 53363)	100 N (DIN 53515)
Temperature resistance	0 °C - 40 °C	0 °C - 40 °C

2.3 Windows

Dimensions: W x H: 640 mm x 580 mm.

2.3.1 Required Daylight Width

DLW	Available no. of columns
5.500 mm – 5.879 mm	6
5.880 mm – 6.669 mm	7
6.670 mm – 7.459 mm	8
7.460 mm – 8.249 mm	9
8.250 mm – 9.039 mm	10
9.040 mm – 9.9829 mm	11
9.830 mm – 10.619 mm	12
10.620 mm – 11.000 mm	13

2.3.2 Required Daylight Height

DLH	Available no. of rows	CC
2040 mm	1	1600 mm

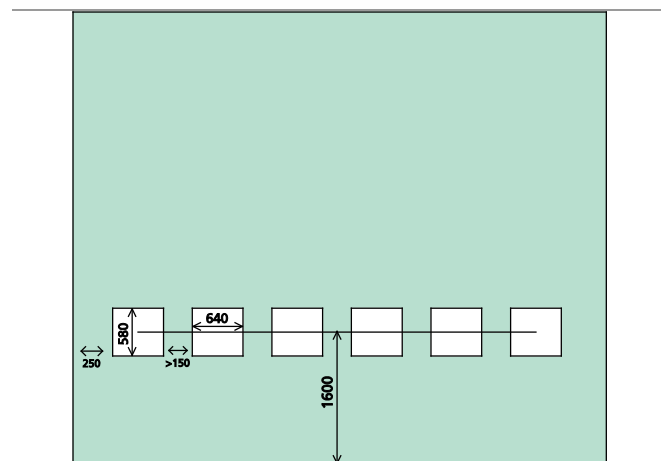

3. CEN Performance

Characteristic	Standard	Test acc.	Result	Value
Wind load	EN 12424	EN 12444	Class 1*	450 Pa (N/m ²)
Water permeability	EN 12425	EN 12489	Class 1	30 Pa (N/m ²) water spray for 20 minutes
Air permeability	EN 12426	EN 12427	Class 1	24 m ³ /m ² /h at 50 Pa
Safe openings	EN 12453	EN 12445	Pass	
Mechanical resistance	EN 12604	EN 12605	Pass	
Unintended movements	EN 12604	EN 12605	Pass	
Thermal resistance	EN 12428			6,02 w/m ² K
Performance (cycles)	EN 12604	EN 12605	1.000.000	

* Indicated wind-load classification is for maximum dimension. For doors up to W 7000 mm x H 5500 mm: class 2



4. Building and space requirements

4.1 Building preparations

4.1.1 Installation preparations

The door is pre-assembled in the factory as much as possible to ensure that installation can be carried out easily and quickly. The door is installed directly on the wall. A forklift truck is needed to raise the frame to the wall.

The fixation of the wall must be of an adequate strength to sustain the wind load as well as the blow of a collision.

4.1.2 Electrical preparations

The following environment criteria and electrical supplies are required for the operator to function properly:

Voltage supply:	220V - 240V 1-phase
Power:	1,5 kW 25A or 32A
Frequency:	50Hz - 60Hz
Degree of protection:	Operator: IP65 Control unit: IP54
Temperature working range:	0 °C to +40 °C

4.2 Space requirements

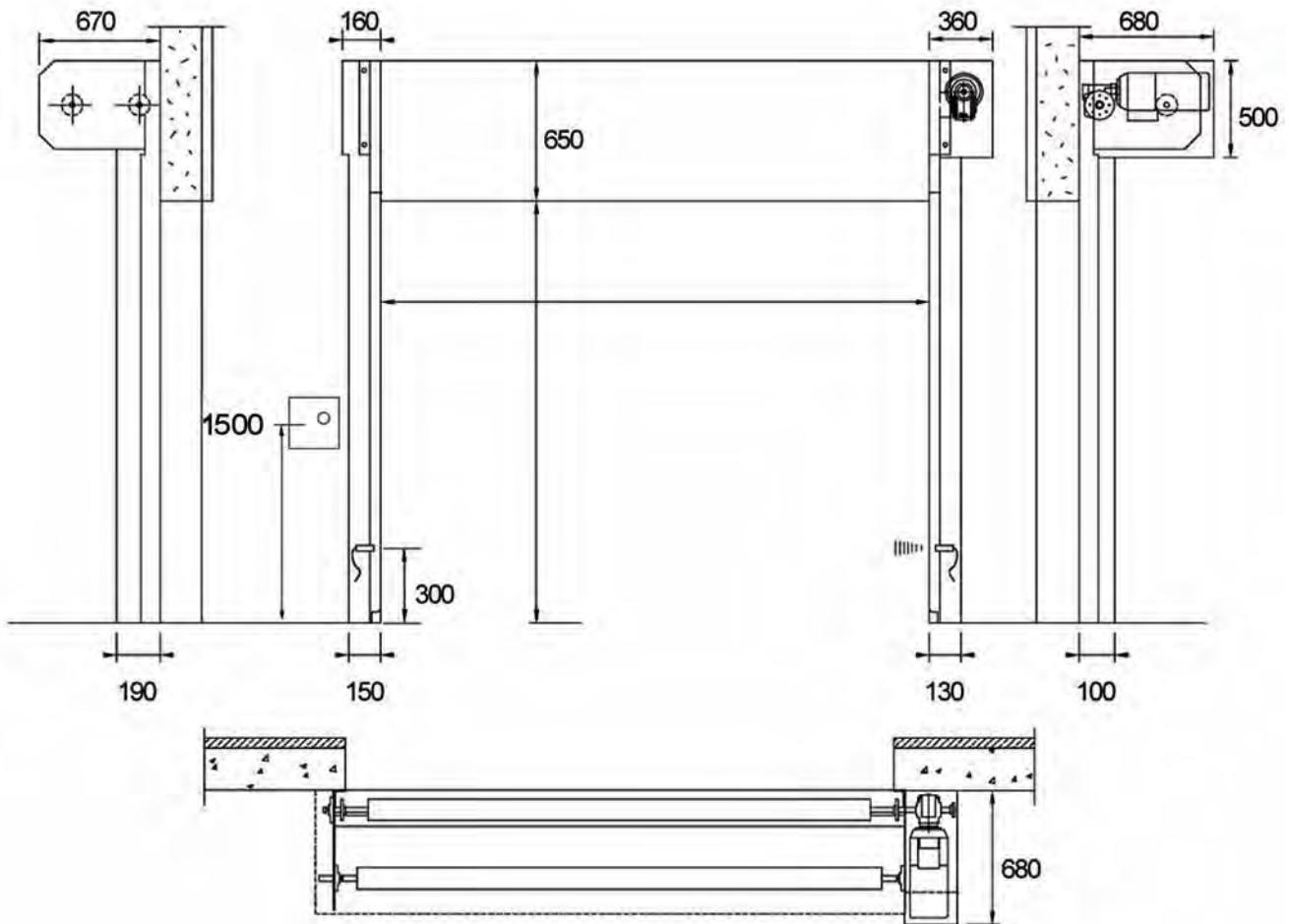



5. Service



These keys open doors to better business

Regardless of their function, age or manufacturer, your industrial doors and dock loading systems have an important role in the flow of your business. That's why it makes sense to plan their maintenance long before the need for service occurs.

A Key Customer Service agreement from Crawford is your best assurance of safe and trouble-free door and dock operation. By becoming a key customer, you not only reduce the risk of breakdowns, but also guarantee compliance with local regulations and the new harmonised EU standards. You also ensure that your doors and dock loading systems retain their classifications for wind load, air permeability, water penetration and more.

Four types of Key Customer Service agreement – Green, Yellow, Blue and Red – allow us to tailor our service to your specific needs. Based on the role of your doors and dock loading systems, and the intensity with which you use them, you receive service that provides the perfect balance of economy, safety and security.

Best of all, the maintenance is performed by Crawford's renowned team of service technicians. As a qualified specialist in industrial doors and dock loading systems, we have the knowledge and skills to service any door or dock, regardless of its type, age or manufacturer. With Crawford as a single source for all your door and docking equipment brands, you can easily reduce costs while increasing equipment availability.

6. Index

A

Access and automation.....	9
Acoustic signal	10
Additional functions.....	11
Airlock	9
Automatic closing (standard).....	10
Automatic control functions	10

B

Basic control functions.....	9
Bottom edge	6
Building and space requirements.....	15
Building preparations.....	15

C

CEN Performance	14
Chain hoist	8
Colours.....	6
Construction.....	6
Control unit.....	8
Copyright and Disclaimer	
Notice	2
Covers	7

D

Daylight width and height... ..	13
Description	5
Dock management	12
Door curtain	6
Door drive system	8

E

Electrical preparations.....	15
External control functions.....	9
External push button box.....	9

F

Fabric roll.....	7
Fabric specifications.....	13
Facility management	12
Features.....	3

G

General.....	5, 7, 8
--------------	---------

H

Header box.....	7
-----------------	---

I

Installation preparations	15
Interlocking.....	9

L

Lights	11
--------------	----

M

Magnetic loop	10
Material	6
Monitoring systems.....	12

O

Operating system	8
Operator	8
Options	5

P

Performance	3
Photocell open door	10
Pull-rope switch.....	9

R

Radar.....	10
Reduced opening	9
Remote control.....	9
Required Daylight Height.....	13
Required Daylight Width.....	13

S

Safety functions.....	10
Safety photocells 1-channel (standard)	10
Saving energy	12
Security enhancement	12
Self repair system	6
Service.....	17
Side columns.....	7
Space requirements.....	16
Specifications.....	13
Standard	5

T

Technical facts	3
Traffic lights - Red & Green ..	11

U

UPS battery backup.....	11
-------------------------	----

W

Warning lights - Green	11
Warning lights - Orange	11
Warning lights - Red	10
Windows	6, 13
Wireless safety edge (standard)	10

Crawford is a leading ASSA ABLOY brand focusing on automated entrance solutions for efficient movement of vehicles and goods. With a complete portfolio of door and docking solutions, an extensive service offer and professional advice, we help customers ensure convenient, safe, secure and energy saving operations around-the-clock.

Crawford is represented in more than 30 countries and is part of ASSA ABLOY Entrance Systems, which also includes the globally recognized Megadoor and Besam brands.

www.crawfordsolutions.com

