



# Copyright and Disclaimer Notice

Although the contents of this publication have been compiled with the greatest possible care, ASSA ABLOY Entrance Systems cannot accept liability for any damage that might arise from errors or omissions in this publication. We also reserve the right to make appropriate technical modifications/replacements without prior notice.

No rights can be derived from the contents of this document.

Color guides: Color differences may occur due to different printing and publication methods.

ASSA ABLOY, Crawford, Megadoor and hafa, as words and logos, are examples of trademarks owned by ASSA ABLOY Entrance Systems or companies within the ASSA ABLOY Group.

Copyright © ASSA ABLOY Entrance Systems 2006-2011

No part of this publication may be copied or published by means of scanning, printing, photocopying, microfilm or any other process whatsoever without prior permission in writing by ASSA ABLOY Entrance Systems.

All rights reserved

# Technical facts

## Features

Sizes - nominal length*	2000, 2500, 3000 mm
Sizes - nominal width	2000, 2200 mm
Vertical working range	Above dock: 0 - 520 mm Below dock: 0 - 460 mm
Platform tear plate	Thickness: 8 mm (8/10)
Surface treatment:	Standard: RAL 5010 RAL 6005 Option: RAL 3002 RAL 9005 Hot dip galvanised
Control Unit	Supervision 205A, i205, i305 Fault & service indicator

\* Other sizes are available on request

## Performance

Load capacity:	6 tonnes (60kN)
Max. point load:	6,5 N / mm <sup>2</sup> (8 mm tear plate)
Motor hydraulic unit:	1,5 kW
Mains supply:	400V 3-phase, 230V 3-phase
Control unit protection class:	Supervision Series: IP 65
Allowable oil types:	Shell Tellus DO 10 (-20°C - +60°C) AeroShell Fluid 41 (-30°C - +60°C) Fuchs Plantolube Polar 15S (-20°C - + 60°C)
Magnetic valves:	24V/DC 18W S1
Surface treatment paint class 1:	80 µm Corrosive Category C2 M acc. DIN EN ISO 12944-2
Surface treatment paint class 3:	160 µm Corrosive Category C3 M acc. DIN EN ISO 12944-2
Surface treatment galvanised:	Hot dip galvanised 80 µm Corrosive category C4 & C5-I M acc. DIN EN ISO 12944-2

Q1.0 - 2011

# Contents

Copyright and Disclaimer Notice .....	2
---------------------------------------	---

Technical facts.....	3
----------------------	---

Features .....	3
Performance .....	3

1. Description.....	6
---------------------	---

1.1	General.....	6
1.1.1	Application .....	6
1.1.2	Mode of operation.....	6
1.1.3	Overview.....	6
1.1.4	Standard.....	6
1.1.5	Options.....	6
1.2	Telescopic Lip.....	7
1.2.1	Lip material.....	7
1.2.2	Lip shapes.....	7
1.3	Platform .....	7
1.3.1	Insulation system .....	7
1.3.2	Platform tear-plate thickness .....	7
1.3.3	Slip protection / noise reduction .....	7
1.4	Surface .....	8
1.4.1	Painting.....	8
1.4.2	Hot galvanising.....	8
1.5	Frames - connection to building.....	8
1.5.1	T - leveller frame for embedding in concrete .....	8
1.6	Docking control systems .....	9
1.6.1	205A Docking control system .....	9
1.6.2	i205 Docking control system.....	9
1.6.3	i305 Docking control system.....	9
1.7	Monitoring systems .....	10
1.7.1	Saving energy .....	10
1.7.2	Security enhancement .....	10
1.7.3	Dock management.....	10
1.7.4	Facility management.....	10
1.8	Equipment .....	11
1.8.1	Buffers.....	11
1.8.2	Crawford Eye.....	12
1.8.3	Wheel chock .....	12
1.8.4	Traffic light .....	12
1.8.5	Dock light.....	12
1.8.6	Parking guides.....	12

2. Selection guide.....	13
-------------------------	----

2.1	Load capacity according to EN 1398 .....	13
2.1.1	Rated load.....	13
2.1.2	Axle load.....	13
2.1.3	Dynamic load.....	13
2.2	Select the load capacity .....	13
2.2.1	Example.....	13
2.3	Select the leveller length .....	14
2.3.1	The calculation .....	14
2.3.2	Example.....	14

Q1.0 - 2011



2.4	Nominal width .....	14
<b>3.</b>	<b>Specifications .....</b>	<b>15</b>
3.1	Dimensions .....	15
3.2	Platform thickness .....	15
3.3	Control units .....	15
3.3.1	Dimensions .....	15
3.3.2	Functions .....	15
<b>4.</b>	<b>CEN Performance .....</b>	<b>16</b>
4.1	Safety according to the European Standard EN 1398 .....	16
<b>5.</b>	<b>Building and space requirements .....</b>	<b>17</b>
5.1	Electrical preparations .....	17
5.2	Pit preparations .....	17
5.2.1	T - frame .....	17
5.2.2	General overview .....	17
<b>6.</b>	<b>Service .....</b>	<b>18</b>
<b>7.</b>	<b>Index .....</b>	<b>19</b>

# 1. Description

## 1.1 General

### 1.1.1 Application

The Crawford 624 isodock is the optimal energy saving solution for loading and unloading in temperature controlled supply chains. The telescopic lip precisely bridges the gap between the ramp and the lorry bed. The leveller is provided with a polyurethane filled insulation construction that achieves an energy cost reduction of up to 75%. The Crawford 624 isodock system meets the standard demands of most loading operations and fully complies with rules and regulations of the European Standard EN 1398.

### 1.1.2 Mode of operation

The operation of the Crawford 624 isodock is based on an electro-hydraulic telescopic lip, controlled by a semi-automatic control unit.

When the dock leveller is raised, the lip extends and the leveller lowers gently onto the lorry bed. After loading or unloading, the leveller is raised again, the lip retracts and the platform returns to its parking position, i.e. to ramp level.

### 1.1.3 Overview

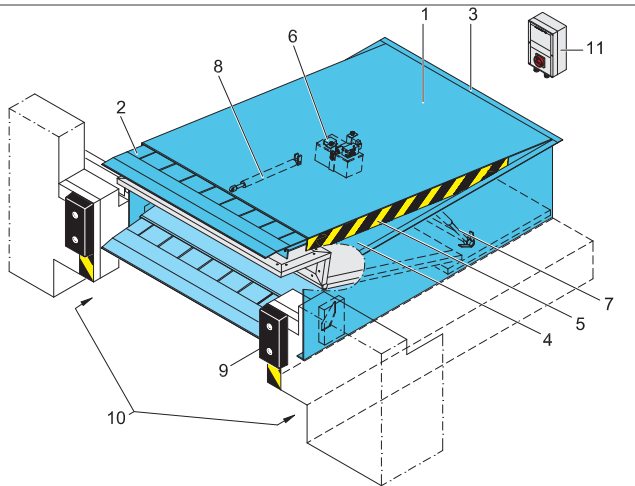

- 1 Leveller platform
- 2 Telescopic lip
- 3 Leveller frame
- 4 Side plates
- 5 Warning stripes
- 6 Hydraulic unit
- 7 Lift cylinders
- 8 Telescopic lip cylinder
- 9 Buffers (option)
- 10 Tail lift recess
- 11 Control unit

### 1.1.4 Standard

Frames - connection to building:	T-frame
Surface:	Painting RAL 5010 or RAL 6005
Hydraulic Equipment	Low noise hydraulic unit Two hydraulic lift cylinders One hydraulic lip cylinder
Lip	Steel lip Lip length 1000 mm
Energy & Ergonomics	EPDM seal Platform insulation

### 1.1.5 Options

Surface	Painting RAL 3002 or RAL 9005 Hot galvanised
Hydraulic equipment	Low temperature oil Bio oil
Lip options	Aluminium lip Tapered lip 2 retracting tongues
Energy & Ergonomics	Slip protection/noise reduction

## 1.2 Telescopic Lip

### 1.2.1 Lip material

#### 1.2.1.1 Steel telescopic lip

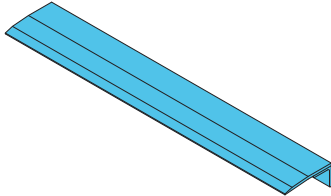

The steel telescopic lip is designed for use by heavy loading equipment. It has a high durability, while it provides medium comfort.

#### 1.2.1.2 Aluminium telescopic lip

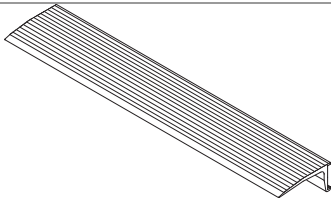

The aluminium telescopic lip is designed to provide maximum comfort to low load-weight loading equipment.

### 1.2.2 Lip shapes

#### 1.2.2.1 Standard telescopic lip

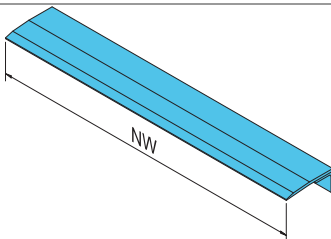

The standard telescopic lip is a single rectangular lip for use with a fleet of vehicles that is a standard size.

#### 1.2.2.2 Tapered telescopic lip

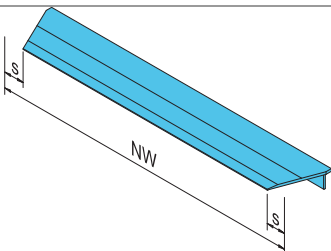

A tapered telescopic lip ensures that the lip reaches the lorry bed, even when the lorry is not parked in the exact centre position. Avoids damage to the truck and interruptions of the dock-in procedure.  $s = 100$  mm

#### 1.2.2.3 2 retracting tongues

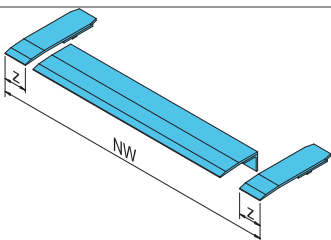

For applications with vehicles of different widths, the telescopic lip can be provided with 2 retracting tongues. On each side a 140 mm wide segment is pushed inside when a smaller vehicle docks.

## 1.3 Platform

### 1.3.1 Insulation system

The Crawford 624 isodock is designed with an insulation system underneath the platform. This insulation is constructed from 40mm thick panels that are filled with polyurethane.

The construction has one hinge connection that allows the third panel to always maintain contact with the bottom panel when the platform is moving.

The insulation panels are equipped with EPDM seals on all sides to maximise the insulation value of the system.

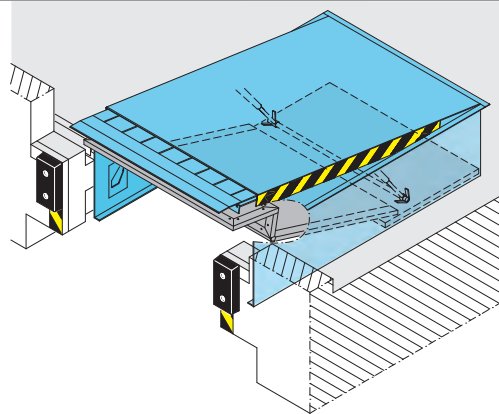

### 1.3.2 Platform tear-plate thickness

The 8 mm (8/10) tear-plate is designed for loading and unloading with typical 4 wheel pneumatic-tired fork-lift trucks, and is also suitable for handling equipment with high point loads, such as electric pallet trucks.

### 1.3.3 Slip protection / noise reduction

Applying a polyurethane slip protection coating on the lip and platform ensures a durable non-slip and noise reduction surface. The effect is a smooth and comfortable surface for handling equipment that is less receptive to wear and tear.

The PU coating material is resistant to impact, to thermal impact and most types of chemicals and it has a high loading capacity.

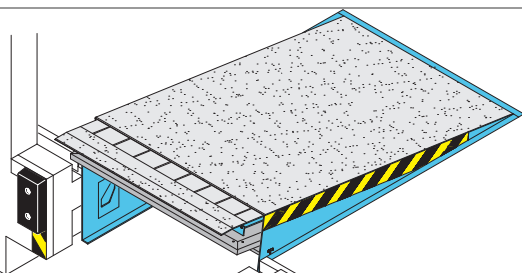

## 1.4 Surface



### 1.4.1 Painting

#### 1.4.1.1 Colours

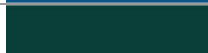
The dock leveller standard finish is painted. The standard colours are:

	RAL 5010
	RAL 6005

Colours available as option are:

	RAL 3002
	RAL 9005

#### 1.4.1.2 Standard paint class

If the dock leveller is to be used in a rural area, the standard finish is:

- Paint class 1; 80 µm factory painted for corrosive category C2 M

#### 1.4.1.3 Paint classes

If the dock leveller is to be used in an urban or industrial atmosphere, or in a coastal area, it may be appropriate to select an alternative paint class with increased resistance to corrosion C3 M.

- Paint class 3; 160 µm factory painted for corrosive category C3 M

### 1.4.2 Hot galvanising

To increase corrosion protection to C4 for saline coastal areas or C5-I for aggressive or humid atmospheres, the dock leveller can be delivered with hot dip galvanised (80 µm) steel parts.

## 1.5 Frames - connection to building

The frame is the leveller's connection point to the building and a rigid support for the leveller. The Crawford 624 isodock is available with one frame system.

### 1.5.1 T - leveller frame for embedding in concrete

The T-frame is installed in one step. The leveller is directly embedded in concrete.

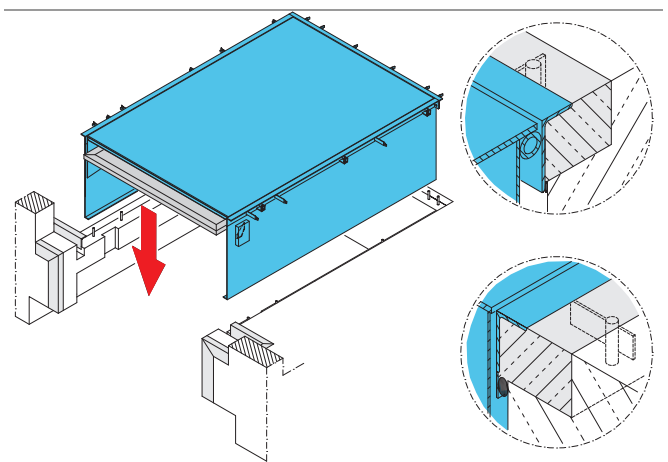

## 1.6 Docking control systems

### 1.6.1 205A Docking control system



- Hold-to-run button to lift platform.
- Hold-to-run button to position the lip on the truck bed.
- Impulse auto button to put the leveller back in parking position.
- Mains isolator or emergency stop button.

### 1.6.2 i205 Docking control system



- Hold-to-run button to lift platform.
- Hold-to-run button to position the lip on the truck bed.
- Impulse auto button to put the leveller back in parking position.
- Mains isolator or emergency stop button.
- 3-digit display for service diagnostics
- Interface to incorporate Crawford EYE and/or wheel chock.
- Can be connected to Crawford 101 dock management network.

### 1.6.3 i305 Docking control system



- Hold-to-run button to lift platform.
- Hold-to-run button to position the lip on the truck bed.
- Impulse auto button to put the leveller back in parking position.
- Mains isolator or emergency stop button.
- Interface to incorporate Crawford EYE and/or wheel chock.
- Can be connected to Crawford 101 dock management network.
- Designed to operate an overhead sectional door and an inflatable shelter in the docking station.

## 1.7 Monitoring systems

As an option on all our products, a Crawford Monitoring System can be installed. This system helps to ensure efficiency and security in daily operations. All doors or docking stations are connected to the Monitoring System's server, which gives the opportunity to supervise, monitor and report a wide variety of aspects in a facility.



Q1.0 - 2011

### 1.7.1 Saving energy

A monitoring system reduces energy costs and contributes to a better environment. Energy is lost every time a door is open. If a door is open when no truck is at the bay, even more energy is lost.

A Crawford Monitoring System automatically ensures that no door will open unless there is a truck at the bay and even set it to close when there an activity is delayed.

### 1.7.2 Security enhancement

Closing and locking doors is an obvious daily routine. However, checking this manually can be time consuming in a busy facility.

A Crawford Monitoring System can automatically ensure that all doors are closed and locked when they need to be. It can also activate all doors and locks from its remote location, and give a real-time overview of the building's situation.

### 1.7.3 Dock management

A good way to increase throughput and thereby efficiency at a logistics facility is to reduce the time of having no truck – or the wrong truck – at a loading bay.

A Crawford Monitoring System makes visible – in real-time – which bays are occupied or free, and for how long. It makes it possible to reserve bays for docking activities and to inform drivers via SMS. Since it incorporates information from cameras and other inputs (RFID, card readers, etc.), the system stays updated in real-time.

### 1.7.4 Facility management

The Crawford Monitoring System gives a real-time service status for all your door and docking equipment. If an error code occurs, the Crawford service organisation is automatically notified, and will respond quickly. Other maintenance information can easily be integrated, further reducing the overall costs.

## 1.8 Equipment

### 1.8.1 Buffers

Buffers placed in front of the dock leveller absorb the energy of a vehicle that accidentally or intentionally hits the building. Buffers are available in various sizes, in fixed or moving models, and with rubber finishing or steel plate and spring function.

#### 1.8.1.1 RS

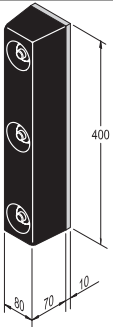

##### Application

The RS buffer is the economical solution for docking stations where vehicles of equal sizes load and unload.

#### 1.8.1.2 RB

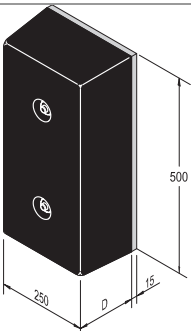

##### Application

The RB buffer is a large fixed rubber. It is the universal building and vehicle protection solution.

Available depths:

- 90 mm
- 140 mm

#### 1.8.1.3 RB with steel front plate

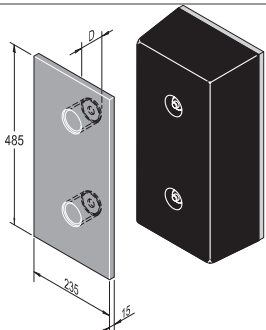

##### Application

The RB buffer with steel protection front plate increases the building protection and the buffer service life.

Available depths:

- 90 mm
- 140 mm

#### 1.8.1.4 RB with steel front and top plate

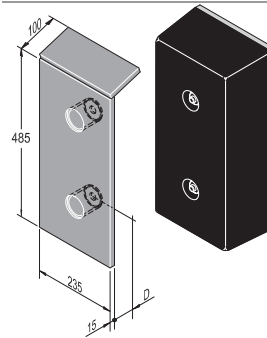

##### Application

The RB buffer with steel protection front and top plate is designed for vehicles with high lorry beds like interchangeable open bodies and containers.

Available depths:

- 90 mm
- 140 mm

#### 1.8.1.5 EBH

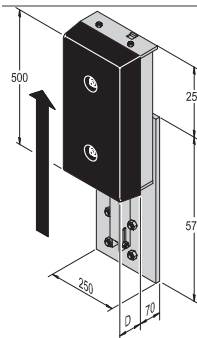

##### Application

The EBH buffer is the ideal solution for docking stations where vehicles of notable height differences load and unload. This buffer can be vertically adjusted by a 'release device'.

Available depths:

- 90 mm
- 140 mm

#### 1.8.1.6 EBF

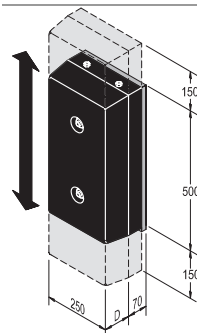

##### Application

The EBF buffer is the ideal solution for docking stations where vehicles are expected to make notable vertical suspension changes when loading or unloading. This buffer follows vertical movements of the vehicle.

Available depths:

- 90 mm
- 140 mm

#### 1.8.1.7 Steel spring buffer 800

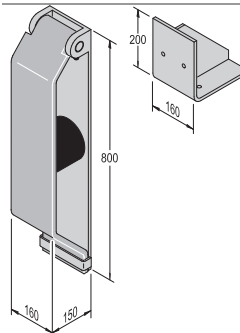

##### Application

The 800 mm steel spring buffer is designed for applications where vehicles generally are higher than ramp level.

**1.8.1.8 Steel spring buffer 600**

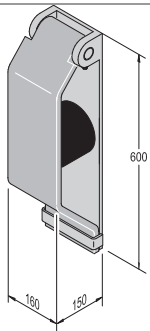

**Application**

The steel spring buffer is the ideal protector of the ramp as well as the vehicle itself.

**1.8.2 Crawford Eye**



The Crawford Eye is an electronic, sensor-based dock-in system, that measures the distance between the vehicle and the building. This makes it easier for the driver to complete the dock-in procedure, but also detects objects or people behind the vehicle.

**1.8.3 Wheel chock**



The wheel chock has an ultrasonic sensor to detect the presence and position of the vehicle and is connected to the dock leveller control panel. If no vehicle is detected, the docking station is blocked for safety reasons. Furthermore, the wheel chock prevent the vehicle from moving during loading/unloading.

**1.8.4 Traffic light**

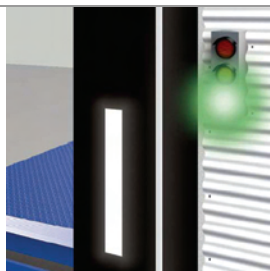

The traffic light system has a sensor above the dock leveller that measures the presence of a vehicle.

If there is no vehicle (dock leveller is free), the traffic light inside gives red, outside gives green.

The traffic light can also be combined with a wheel chock, CrawfordEYE or door/leveller interlocking.

**1.8.5 Dock light**

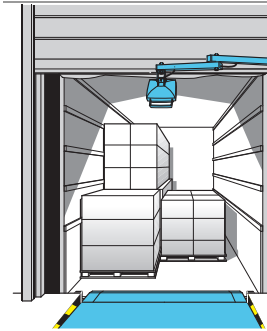

A lorry docked for loading and unloading most likely creates a dark zone which endangers a safe and fast transfer of goods. The dock light ELS is the ideal solution for an optimum of light at the loading bay area and inside the lorry. The wide scattering allows an extensive illumination.

**1.8.6 Parking guides**

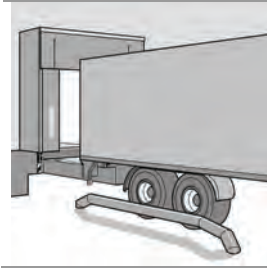

This visual aid makes it easier to park the vehicle and reduces the risk of collision. Especially advantageous for docking stations with wide leveller lips and cushion shelters. Parking guides can be bolted or cast in concrete on the floor before the leveller.

Q1.0 - 2011

## 2. Selection guide

### 2.1 Load capacity according to EN 1398

The EN 1398 describes 3 key definitions about loads.

#### 2.1.1 Rated load

The rated load is the total weight of the goods, the forklift truck and the driver.



#### 2.1.2 Axle load

Axle loads shall be taken acting over two rectangular contact areas at 1 m lateral distance. These areas shall only apply if the actual conditions do not call for more severe loading. The size of the footprint [mm<sup>2</sup>] is derived from the wheel load [N] divided by 2 [N/mm<sup>2</sup>]. The ratio of the rectangular print is W:L = 3:2.

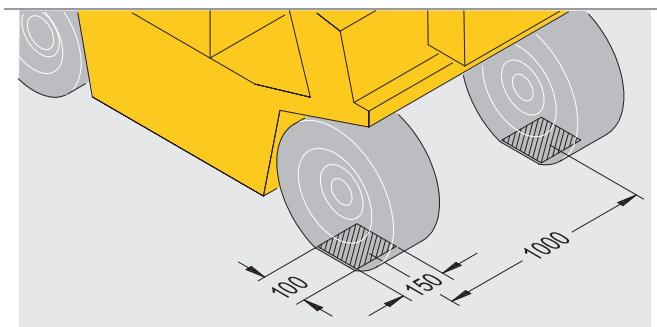

In the drawing measures for a leveller with a load capacity of 60kN.

#### 2.1.3 Dynamic load

The dynamic load is the movement of the rated load and is the pressure on the leveller platform caused by the moving forklift truck.

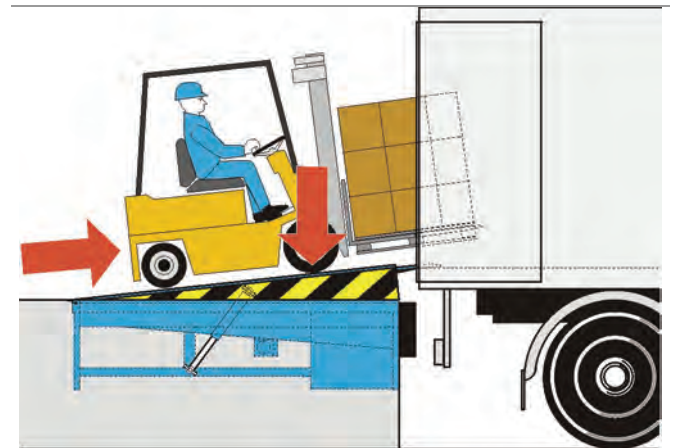

### 2.2 Select the load capacity

The load capacity of a dock leveller must always be higher than the rated load.

#### 2.2.1 Example

Weight of forklift truck	3600 kg
Weight of goods	1500 kg
Weight of driver	100 kg
Total weight/rated load	5200 kg
Suitable load capacity of the leveller	6000 kg/60kN

The 6 tonnes (60kN) 624 isodock is as a standard equipped with a tear plate of 8 mm (8/10).

## 2.3 Select the leveller length

When determining the leveller length, measure the maximum height difference between the truck bed and the dock level. Next, determine which vehicles will be used and lookup the maximum gradient the vehicles are allowed to be used on.

Vehicle	Max gradient
Roll cage	3%
Hand pallet truck	3%
Electric pallet truck	7%
Forklift truck (battery)	10%
Forklift truck (gas / petrol)	15%

### 2.3.1 The calculation

Minimal leveller length = height difference / gradient (%)

### 2.3.2 Example

Vehicle:	Electric pallet truck (max 7% gradient)
Truck height:	1350 – 1000 mm
Dock height:	1150 mm

The difference between Truck height and Dock height = 175 mm

$175 \text{ mm} / 7\% = 2500 \text{ mm}$  leveller length

## 2.4 Nominal width

The Crawford 624 isodock is available with a nominal width of 2000 mm or 2200 mm. The correct nominal width must exceed the widest loading vehicle by at least 700 mm.

# 3. Specifications

## 3.1 Dimensions

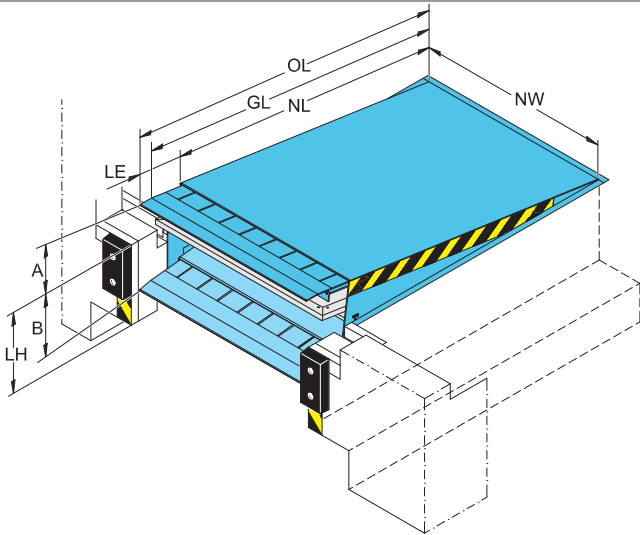

NL	Nominal length
OL	Overall length
GL	Gradient length
NW	Nominal width
LE	Leveller extension
LH	Leveller height
A	Working range above dock level
B	Working range below dock level

NL	Nominal length	2000	2500	3000
LH	Leveller height	830	830	900
PD	Pit depth	850	850	920
A	Range above dock	380	450	520
B	Range below dock	460	450	450
OL	Overall length	3000	3500	4000
GL	Gradient length	2860	3360	3860

Nominal width (NW) 2000, 2200 for all sizes.

## 3.2 Platform thickness

Thickness	Max. point load
8 mm	6,5 N /mm <sup>2</sup>

## 3.3 Control units

### 3.3.1 Dimensions

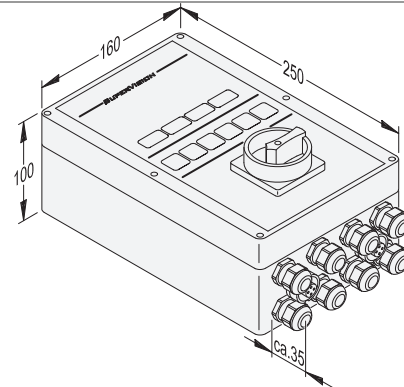

### 3.3.2 Functions

Functions included	205A	i205	i305
Hold to run button	<input checked="" type="checkbox"/>	<input checked="" type="checkbox"/>	<input checked="" type="checkbox"/>
Close (hold to run)	<input checked="" type="checkbox"/>	<input checked="" type="checkbox"/>	<input checked="" type="checkbox"/>
Auto button	<input checked="" type="checkbox"/>	<input checked="" type="checkbox"/>	<input checked="" type="checkbox"/>
Extend lip (hold to run)	<input checked="" type="checkbox"/>	<input checked="" type="checkbox"/>	<input checked="" type="checkbox"/>
Mains isolator	<input type="checkbox"/>	<input type="checkbox"/>	<input type="checkbox"/>
Emergency p. b	<input type="checkbox"/>	<input type="checkbox"/>	<input type="checkbox"/>
400V	<input checked="" type="checkbox"/>	<input checked="" type="checkbox"/>	<input checked="" type="checkbox"/>
230V	<input type="checkbox"/>	<input type="checkbox"/>	<input type="checkbox"/>
Maintenance indicator	<input checked="" type="checkbox"/>	<input checked="" type="checkbox"/>	<input checked="" type="checkbox"/>
Memory function	<input checked="" type="checkbox"/>	<input checked="" type="checkbox"/>	<input checked="" type="checkbox"/>
Fault indicator	<input checked="" type="checkbox"/>	<input checked="" type="checkbox"/>	<input checked="" type="checkbox"/>
Integrated clock	<input type="checkbox"/>	<input checked="" type="checkbox"/>	<input checked="" type="checkbox"/>
BUS network interface	<input type="checkbox"/>	<input checked="" type="checkbox"/>	<input checked="" type="checkbox"/>
3-Digit display	<input type="checkbox"/>	<input checked="" type="checkbox"/>	<input checked="" type="checkbox"/>
CrawfordEYE	<input type="checkbox"/>	<input type="checkbox"/>	<input type="checkbox"/>
Wheel chock	<input type="checkbox"/>	<input type="checkbox"/>	<input type="checkbox"/>
Door control	<input type="checkbox"/>	<input type="checkbox"/>	<input checked="" type="checkbox"/>
Shelter control	<input type="checkbox"/>	<input type="checkbox"/>	<input checked="" type="checkbox"/>

Standard  
 Option / Available

Q1.0 - 2011

## 4. CEN Performance

### 4.1 Safety according to the European Standard EN 1398

- Emergency Stop Function.
  - Safety valves block lowering movement after max. 6% of the nominal length of the leveller.
  - Two lift cylinders make sure the leveller stops in a horizontal position.
- Free floating position.
- Platform torsion. Lateral deflection of at least 3% of nominal width.
- Toe guards cover gap between platform and pit in leveller's highest position.
- Working range gradient max. 12,5% (~7°).
- Warning stripes on side plates and on frame (black/yellow).

# 5. Building and space requirements

## 5.1 Electrical preparations

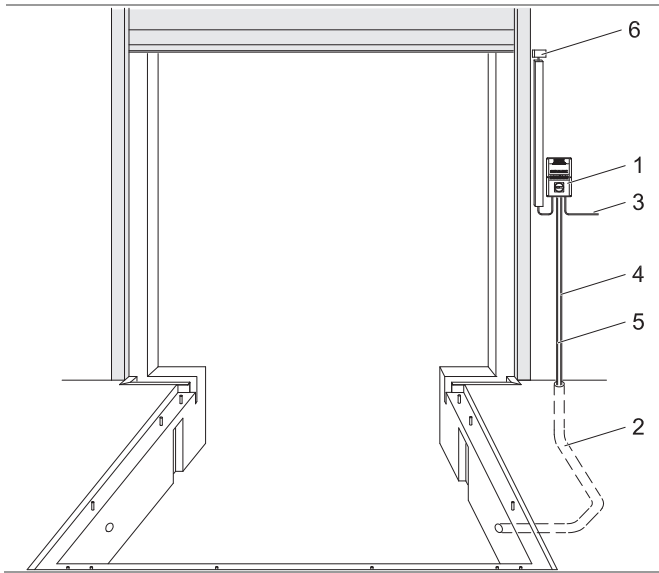

- |   |  |
|---|--|
| 1 | control unit (included in the delivery)  |
| 2 | conduit for wiring internal diameter 70, angles <math><45^\circ</math> (by others) |
| 3 | mains supply: 3/N/PE AC 50 Hz<br>230/400V  |
|   | mains fuse: D0 10 A gL   |
|   | motor power: 1,5 kW  |
| 4 | cable: 7 x 0,75 mm <sup>2</sup>  |
| 5 | motor cable: 4 x 1,5 mm <sup>2</sup>   |
| 6 | optional safety switch on sectional door to disable leveller when door is closed*  |

\*Non standard

## 5.2 Pit preparations

This illustration indicates the required pit preparations for the Crawford 624 isodock.

### 5.2.1 T - frame

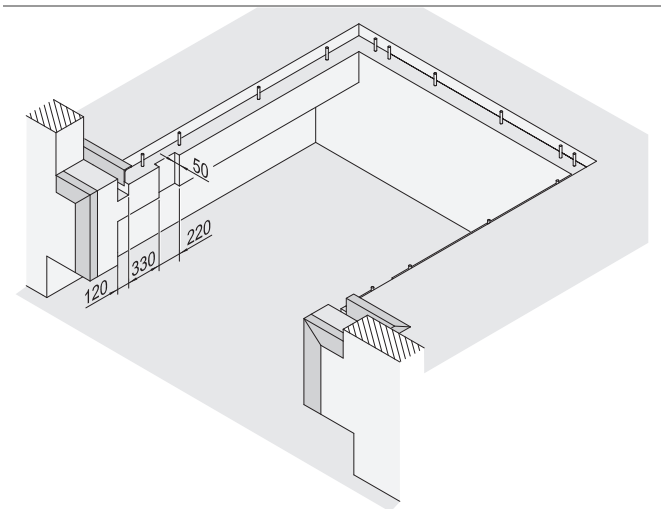

pit drawing 5145.0141

### 5.2.2 General overview

This illustration shows the leveller in parking position. In this position the insulated overhead sectional parking is driven directly onto the horizontal part of the insulation which is installed underneath the dock leveller. The result is perfect sealing.

The Crawford 624 isodock always has a lip length of 1000 mm. The lip needs to be that long in order to reach the loading vehicle, as the complete dock leveller is installed behind the overhead sectional door of the loading bay.

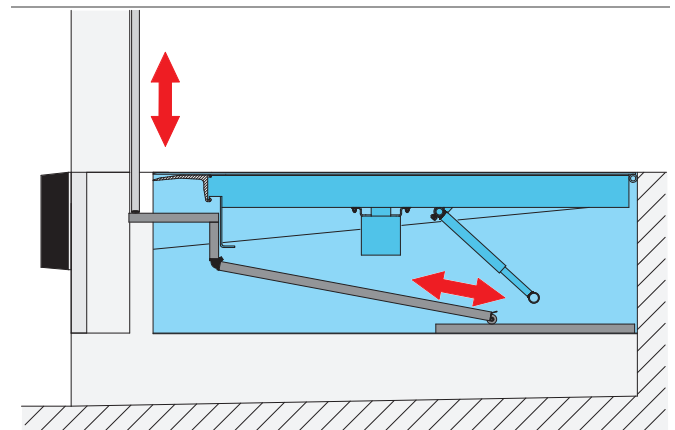

general drawing 5145.0140

Q1.0 - 2011

## 6. Service



### These keys open doors to better business

Regardless of their function, age or manufacturer, your industrial doors and dock loading systems have an important role in the flow of your business. That's why it makes sense to plan their maintenance long before the need for service occurs.

A Key Customer Service agreement from Crawford is your best assurance of safe and trouble-free door and dock operation. By becoming a key customer, you not only reduce the risk of breakdowns, but also guarantee compliance with local regulations and the new harmonised EU standards. You also ensure that your doors and dock loading systems retain their classifications for wind load, air permeability, water penetration and more.

Four types of Key Customer Service agreement – Green, Yellow, Blue and Red – allow us to tailor our service to your specific needs. Based on the role of your doors and dock loading systems, and the intensity with which you use them, you receive service that provides the perfect balance of economy, safety and security.

Best of all, the maintenance is performed by Crawford's renowned team of service technicians. As a qualified specialist in industrial doors and dock loading systems, we have the knowledge and skills to service any door or dock, regardless of its type, age or manufacturer. With Crawford as a single source for all your door and docking equipment brands, you can easily reduce costs while increasing equipment availability.

# 7. Index

## 2

2 retracting tongues.....	7
205A Docking control system ...	9

## A

Aluminium telescopic lip .....	7
Application .....	6
Axle load.....	13

## B

Buffers .....	11
Building and space requirements	17

## C

CEN Performance .....	16
Colours .....	8
Control units .....	15
Copyright and Disclaimer Notice .....	2
Crawford Eye.....	12

## D

Description.....	6
Dimensions.....	15
Dock light.....	12
Dock management .....	10
Docking control systems.....	9
Dynamic load.....	13

## E

EBF .....	11
EBH .....	11
Electrical preparations .....	17
Equipment .....	11
Example .....	13, 14

## F

Facility management .....	10
Features .....	3
Frames - connection to building	8
Functions.....	15

## G

General.....	6
General overview.....	17

## H

Hot galvanising .....	8
-----------------------	---

## I

i205 Docking control system.....	9
i305 Docking control system.....	9
Insulation system.....	7

## L

Lip material .....	7
Lip shapes .....	7
Load capacity according to EN 1398.....	13

## M

Mode of operation .....	6
Monitoring systems .....	10

## N

Nominal width .....	14
---------------------	----

## O

Options .....	6
Overview.....	6

## P

Paint classes.....	8
Painting.....	8
Parking guides .....	12
Performance .....	3
Pit preparations.....	17
Platform .....	7
Platform tear-plate thickness ...	7
Platform thickness.....	15

## R

Rated load .....	13
RB.....	11
RB with steel front and top plate .....	11
RB with steel front plate .....	11
RS.....	11

## S

Safety according to the European Standard EN 1398 ..	16
Saving energy .....	10
Security enhancement .....	10
Select the leveller length.....	14
Select the load capacity .....	13
Selection guide .....	13
Service.....	18
Slip protection / noise reduction	7
Specifications.....	15
Standard .....	6
Standard paint class .....	8
Standard telescopic lip.....	7
Steel spring buffer 600.....	12
Steel spring buffer 800.....	11
Steel telescopic lip .....	7
Surface .....	8

## T

T - frame.....	17
T - leveller frame for embedding in concrete.....	8
Tapered telescopic lip .....	7
Technical facts .....	3
Telescopic Lip .....	7
The calculation .....	14
Traffic light.....	12

## W

Wheel chock.....	12
------------------	----

Crawford is a leading ASSA ABLOY brand focusing on automated entrance solutions for efficient movement of vehicles and goods. With a complete portfolio of door and docking solutions, an extensive service offer and professional advice, we help customers ensure convenient, safe, secure and energy saving operations around-the-clock.

Crawford is represented in more than 30 countries and is part of ASSA ABLOY Entrance Systems, which also includes the globally recognized Megadoor and Besam brands.

[www.crawfordsolutions.com](http://www.crawfordsolutions.com)

